

California EDUCATOR

California Teachers Association September 2010 Volume 15 Issue 1

*"I like a teacher who gives
you something to take home
to think about besides
homework."*

Lily Tomlin

Strings attached

How corporate foundations are shaping education policy **page 8**

Back-to-school tips

Members share ideas **page 18**

A lesson plan for victory

Educators organize for crucial elections in November **page 20**

What will you leave undone?

No one knows what the future will bring. The important thing is that you and your loved ones are ready and protected with reliable Disability and Life Insurance should the unexpected occur along the way. Wherever your life's path leads, don't leave good protection behind. Standard Insurance Company offers the only CTA-endorsed Disability and Life Insurance coverage, so you know you'll have a more secure journey.

Visit MyCTA at www.cta.org or call us at 800.522.0406 (TTY) to find out how The Standard can protect what's important to you.



For costs and further details of the coverage, including exclusions, any reductions or limitations and the terms under which the policy may be continued in force, please contact Standard Insurance Company at 800.522.0406 (TTY).

Standard Insurance Company, 1100 SW Sixth Avenue, Portland, OR 97204

GP 190-LTD/S399/CTA.1
GP 190-LIFE/S399/CTA.3
SI 14173-CTAvoI



FEATURES

8 Funding with strings attached

- 10 Beware of corporations bearing gifts
- 12 Sacramento schools under corporate control
- 14 Oakland schools suffer from half-baked reforms
- 14 In LAUSD corporate foundations wield enormous power
- 16 Small schools increase segregation in San Diego

18 Back-to-school tips for members

20 A lesson plan for victory

- 21 CTA's recommendation process
- 22 CTA's plan for victory
- 23 Prop. 24: Ensuring corporations pay their fair share
- 24 Social media play key role



On the cover: Student Shiloe Mendoza at Computech Middle School in the Spanish class of Steve Aberle, who is featured in our extended "Back-to-school tips for members." Story on page 18.



MAKING A DIFFERENCE

- 26 Presidents Conference focuses on upcoming elections
- 28 Institute for Teaching gives Mini Grants
- 29 NEA Foundation awards 10 grants to California educators



TAKING A STAND

- 30 Ceres educators settle contract, gain support

ACTION

- 32 Two-thirds requirement blocks budget and greater school funding
- 32 Education Jobs Bill will help rehire over 13,000 California educators
- 33 Assembly panel defeats CTA-opposed rigid layoff bill
- 34 2008 Summary Annual Report for CTA Economic Benefits Trust Member Welfare Benefit Plan
- 35 Heads up: Deadlines and conference dates
- 36 CTA-sponsored and co-sponsored legislation for 2010
- 38 Member profile: Zoe Walrond, California Faculty Association



¡Sí Se Puede! ¿Por Qué No?

BY CTA PRESIDENT DAVID A. SANCHEZ

I want to welcome you all back to another new school year — one that will likely prove to be exceptionally challenging in many ways, but will also give us an opportunity to effect great change. Like never before, we are seeing the profession of teaching under attack. We currently have a federal administration that asks us to compete for education dollars; corporate foundations are increasingly meddling in the classroom, influencing policy that leads to dangerous, experimental reforms; and too many of our state's elected leaders are failing to do their jobs, leaving us — still at this late date — with no budget at all. And that's why the elections this year are so very important: to help fix this broken process.

It's a travesty, really, a downright outrageous situation, that educators — who have day-to-day knowledge of the classroom and intimate, personal understanding of teaching — should be left out of the conversation regarding education reform.

I entered the teaching profession, as did both of my parents, who were lifelong educators, with the intention of making a difference and contributing to the growth of young minds. I personally was fortunate enough to get a first-rate education here in California — a state with such incredible wealth that it dwarfs the economies of entire countries. It's inexcusable that in a place of such abundance, schools are so starved for funds that corporate foundations like the Broad and Gates foundations can dangle sacks of money with strings attached and set their own education policy. For some unknown reason, our elected leaders have lost sight of the fact that public education is a basic right — not a privilege, not something to be bought and sold. Quality public education is what once built California and made it a great state. And quality, affordable education for all is what will once again make it a great state.

As I travel the state, it's clear to me that teachers are distressed by attacks being

made on them, such as the one leveled by a *Los Angeles Times* story in August that used student results from California Standards Tests to evaluate teacher effectiveness for nearly 6,000 United Teachers Los Angeles members. The article was irresponsible and reckless, an oversimplification of a very complex situation. We don't dispute the importance of the data, but to think it provides a comprehensive view of a student or a teacher's effectiveness is ignorant.

Each of us has the responsibility to get involved and try to bring about positive change. It's time that we as educators understand exactly how policy is being made and by whom. From the effects of U.S. Secretary of Education Arne Duncan's Race to the Top competition to corporate foundation influence to our state leaders dragging their heels on producing a state budget — a lot is happening behind the scenes that directly and profoundly affects our classrooms.

We all need to be engaged during this midyear election season. It's of the utmost importance that we elect pro-education candidates like Jerry Brown for governor and Tom Torlakson for state superintendent of public instruction. Both have strong records in support of public education. It's also important that we vote yes on Prop. 24, the Tax Fairness Act, to end \$1.3 billion in special corporate tax loopholes that do not require the creation or protection of one single California job.

We have the opportunity to help turn around California and make our state a leader in public education. To do that we must be part of the conversation. We must talk to our friends, family members and colleagues over the coming months and convey to them the importance of the November election. With continued support from each of us, we will change the status quo and give all of our students the first-rate education they truly deserve.

California EDUCATOR

EDITOR IN CHIEF Dave Earl Carpenter
STAFF WRITER Sherry Posnick-Goodwin
CTA WEB EDITOR Karyn Ferrera Donhoff
CTA WEB EDITOR Tiffany Hasker
EDITORIAL ASSISTANT Craig Hamilton

CTA ELECTED OFFICERS
PRESIDENT David A. Sanchez
VICE PRESIDENT Dean E. Vogel
SECRETARY-TREASURER Gail M. Mendes

BOARD OF DIRECTORS

Larry Allen, E. Toby Boyd, Donald L. Bridge, Tyrone V. Cabell, Mikki Cichocki, Elana Davidson, Don Dawson, Dana Dillon, David Goldberg, Jim Groth, Eric C. Heins, Marty G. Meeden, George Melendez, Theresa Montañó, Mary Rose Ortega, Cynthia Peña, Jim Rogers, Bonnie Shatun, Marc Sternberger, Michael Stone, Curtis Washington

EXECUTIVE DIRECTOR Carolyn Doggett
ASSOCIATE EXEC. DIRECTOR Rebecca Zoglmann
COMMUNICATIONS MANAGER Jonathan Goldman

CONTRIBUTORS

Scott Buschman, Dave Crosland, Len Feldman, Dina Martin, Mike Myslinski, Kamran Nasser, Marcos Sorensen

EDITORIAL INFORMATION

California Educator is published for the information and edification of its members. The editorial philosophy is governed by the policies of CTA. Articles and advertising reflect that philosophy.

Letters to the editor may be sent to editor@cta.org.

Publication of advertising in the *California Educator* does not indicate CTA approval of the product or of the companies that purchase advertising.

Advertising rate card and information is available from WebSolutions, Media Division, 5666 Spruce Harbor Court, Las Vegas, NV 89122 (702) 838-3434; FAX (702) 838-3355

CTA/NEA membership dues for the fiscal year, Sept. 1-Aug. 31, are \$805, including a \$20 voluntary contribution. Up to \$26.30 of CTA annual dues is designated for CTA/ABC political activities to support state and local candidates and/or initiatives and is not deductible for income tax purposes.

Subscription to the *California Educator* is \$10/year, available only to persons or institutions not eligible for CTA/NEA membership.

California Educator (ISSN 1091-6148) is published monthly except January, July and August for \$6.17 per year (included in dues) by:

CALIFORNIA TEACHERS ASSOCIATION
1705 Murchison Dr., Burlingame, CA 94010-4583
(650) 697-1400; FAX (650) 552-5002

editor@cta.org, www.cta.org

Postmaster: Send change of address to *California Educator*, P.O. Box 4178, Burlingame, CA 94011-4178.

Periodicals Postage Paid at Burlingame, CA, and additional mailing offices.

¡Sí Se Puede! [Yes we can! Why not?], words inspired by César Chávez,
¿Por Qué No? encourage us to remember that, together, we can achieve great things.



what's new at CTA.ORG



Registering or Updating your Beneficiary Form

Interested in registering or updating the beneficiaries of your automatic CTA Death & Dismemberment Plan? If so, log in using the orange We Are CTA box, sign in (registration is required for first-time users), click on My Profile next to You Are CTA in the orange box, and then click on the Update Beneficiaries tab and complete the fields.

www.cta.org



School's Back in Session

With summer behind us, get tips on getting families involved in their children's education and the learning process for yearlong support and academic success.

www.cta.org/family



Measuring Teacher Effectiveness

CTA responds to the controversial *Los Angeles Times* article, "Grading the Teachers: Who's Teaching L.A.'s Kids?" Check it out, get involved, and help set the record straight.

www.cta.org/latimes

For additional Educator content, look for our web exclusives at cta.org

Create a cartoon concept

We invite members to send in cartoon concepts for future issues of the *Educator*. All we ask is that your ideas deal with current events in education and captions are no longer than one sentence long. Please send your cartoon ideas through mail, fax or e-mail.

address: California Educator Magazine
CTA Communications
1705 Murchison Drive
Burlingame, CA 94010-4583

e-mail: editor@cta.org **fax:** (650) 552-5002



Dave Crosland, hiredmeat@gmail.com

"Thanks to a generous grant from MegaBuck\$ Foundation, we'll all be wearing bunny suits at school this year!"

Teacher effectiveness should not be measured by test scores alone

Editor's note: In late August, as this issue was headed to press, CTA learned that the *Los Angeles Times* had published an article using student results on California Standards Tests to evaluate teacher effectiveness for nearly 6,000 UTLA third- through fifth-grade teachers.

Publishing the database assembled by the *Times* as an accurate measure of teacher effectiveness or even as a "value-added" assessment model is irresponsible and disrespectful to the hardworking teachers of Los Angeles. The *Los Angeles Times* model oversimplifies what defines an effective teacher and is based solely on one set of student test scores — tests that were never designed to measure teacher effectiveness or even student growth. The California Standards Tests are designed to measure grade-level standards, not student growth from the beginning of the school year to the end of the year. So trying to use that single test to create a value-added model in Los Angeles is impossible.

In addition, all education research has concluded that using value-added models as a primary measure for evaluating teachers is not appropriate, as the mea-

asures are too unstable and too vulnerable. It is impossible to fully separate out the influences of students' other teachers, as well as school conditions, classroom assignments, and student attendance.

The following letter is from CTA member Larry Wiener in response to the *Los Angeles Times'* misuse of test score data.

I am a teacher for the Alhambra School District. Terry Skotnes, our executive director, suggested that I send this story to you in response to the testing frenzy we are all facing.

Last year, part of my assignment was to work as an intervention specialist with at-risk students at a K-8 school. I worked in collaboration with a counselor whose title was intervention adviser.

In January, an eighth-grader came to our school with great needs. He had failed most of his classes in his other schools and was doing community service for driving without a license. At one parent conference he even said that he would drop out of school if he could.

My partner and I both gave him a great deal of time because he was so at risk, but we saw potential, and he seemed to respect us. We had family conferences and enlisted the family, who made some major changes in the

way they handled him. He improved greatly.

I just talked with the mom last night. I heard that he went to summer school and took algebra and passed with a C. He even got an A in the first part of the class. He has had no trouble with the law according to the mom.

I consider this a major turnaround, but had we been totally obsessed with test scores, there would be no reason to put the effort into this boy that we did. Because he came in January his test scores would not count even if he did get to proficient, which would be quite unlikely in the three months between his entry and the testing time.

We feel we made a definite difference in a needy boy's life, but this accomplishment was not reflected in the test scores. I'm sure all over the state there are educators doing important work that doesn't show up in test scores. I felt CTA needed to know about this to use as an example.

Larry Wiener

Alhambra Teachers Association



Are you a fan?

Members are weighing in on Facebook. Give us your thoughts at: www.facebook.com/californiateachersassociation

LETTERS

TO THE EDITOR

Dear Editor:

I was extremely happy to read about other one-room schools in California in the June 2010 issue of *California Educator* ("Last of the one-room schoolhouses"). I am starting my tenth year at Bear Valley School. We are a one-room schoolhouse in the Sierra Nevadas. I spent my last nine years as the English/history teacher for the Bear Valley High School, which operated in Bear



Valley School. Now we are only an elementary school with the closure of Bear Valley High School. These schools offer a special education which offers one-on-one education to all students. It's sad to hear of schools like ours being closed. Schools really exist as a community center, and when that is gone, well, it is sad.

Stephanie Bowen

Alpine County School Employees Association

Dear Editor:

With regard to the article "Meet Generation Z" in the February 2010 issue of *California Educator*, yes, there are ups and downs to this form of communication [texting] — but if you are the parent or teachers of this generation of kids, you better start thumbing!

Elizabeth Sassman

Auburn Union Teachers Association

calendar

sep 2010	<input type="checkbox"/> Sept. 21	International Day of Peace in Education
oct 2010	<input type="checkbox"/> Oct. 1-3 <input type="checkbox"/> Oct. 8-10 <input type="checkbox"/> Oct. 15-17 <input type="checkbox"/> Oct. 22 <input type="checkbox"/> Oct. 22-24 <input type="checkbox"/> Oct. 29-31	Region II Leadership Conference, Reno CCA Fall Bargaining/Leadership Conference Region I Leadership Conference, Asilomar Incentive grants deadline for winter conferences CTA State Council of Education, Los Angeles GLBT Conference, Rancho Mirage
nov 2010	<input type="checkbox"/> Nov. 1 <input type="checkbox"/> Nov. 2 <input type="checkbox"/> Nov. 5 <input type="checkbox"/> Nov. 14-20	Deadline to change voluntary contribution General election GLBT Safety in Schools grant/scholarship deadline American Education Week
dec 2010	<input type="checkbox"/> Dec. 8-9	Secondary Literacy Summit X, Costa Mesa
jan 2011	<input type="checkbox"/> Jan. 14-16 <input type="checkbox"/> Jan. 21-23 <input type="checkbox"/> Jan. 28-30	Issues Conference, Las Vegas Good Teaching Conference, San Jose Region III Leadership Conference, Torrance
feb 2011	<input type="checkbox"/> Feb. 4-6 <input type="checkbox"/> Feb. 11-13 <input type="checkbox"/> Feb. 25-26	CTA State Council of Education, Los Angeles CCA Winter Advocacy Council NEA Pacific Region Conference, Portland, OR
mar 2011	<input type="checkbox"/> March 2 <input type="checkbox"/> March 4-6 <input type="checkbox"/> March 18-20	Read Across America Equity and Human Rights Conference, San Jose Good Teaching Conference, Orange County

Flip through pages, click links, print stories, e-mail copies to friends and many other great features.



Check out the new **interactive digital version of California Educator** online! Visit us at www.cta.org.

Welcome Back

She's ready for the new school year. We can help make sure you are too, [at neamb.com](http://neamb.com).

Perks
Find special savings on clothing, supplies, books, and more right in time for school

Plans
Engaging lesson plans and rewards that will help you keep your students on track

Progress
Expand your career with online professional development through the NEA Academy

Be Prepared!
Start the year off right [at neamb.com](http://neamb.com)

YOUR DEDICATION DRIVES OURS®



WS050910

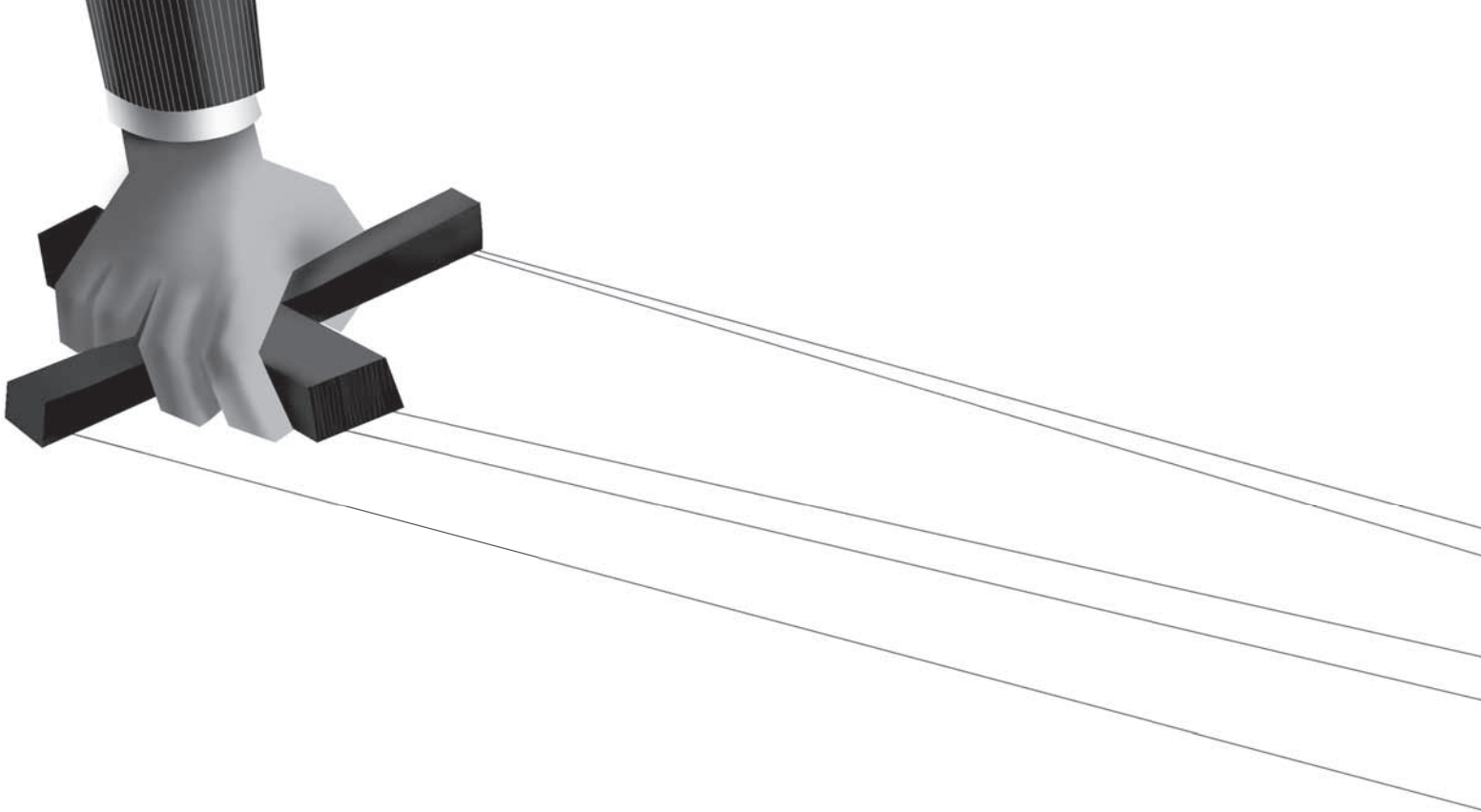

funding *with* **strings** **atta**

How corporate foundations are shaping education policy

A troubling power shift is occurring in public education: Corporations are wielding greater and greater influence over education policy and how the federal government funds public education. Corporate dollars are increasingly swaying policymakers to enact experimental education reforms — many of which are unproven, and some of which actually harm our schools rather than help them.

Reforms like U.S. Secretary of Education Arne Duncan's Race to the Top, which provides misguided mandates such as paying teachers based on student test scores and creating charters that operate independently of local school boards, are a result of lobbying by corporate foundations controlled by

wealthy benefactors such as Eli Broad, Bill and Melinda Gates, and the Walton family. It's no surprise that Duncan's top officials come from the ranks of corporate foundations which, in the name of philanthropy, promote strict accountability measures that punish our schools rather than help them.

While the money from corporations is intended as a charitable donation, the ideology behind them — for the most part with the goal of running schools like a business — doesn't always mean the best results for our public schools. After all, students aren't widgets to be bought and sold. They come with disparate abilities and needs and sometimes require individualized attention. And

ached

because in this harsh economic climate school districts are especially desperate for money — and corporate philanthropists generally have very deep pockets — schools may take donations without asking important questions. Many reforms imposed by foundations run counter to the aim of providing quality public education to all children in all California schools.

Back in March 2004, *California Educator* asked an important question in an article titled “Is it philanthropy? Or corporate meddling?” Concerns were voiced about corporate foundation grants with strings attached for privatized charters, scripted learning, and the breakup of large schools into small schools. >>>



Stories by **Sherry Posnick-Goodwin** • Photos by **Scott Buschman**

Beware of corporations bearing gifts

The story also took a critical look at the role corporate foundations play in training administrators from the private sector to govern schools in a top-down, authoritarian style. Six years later, many of those concerns have been justified: Corporate grants for charter schools have hurt public schools; the breakup of large schools into small schools has not been cost-effective; and foundation-trained administrators are causing problems.

The question “Is it philanthropy or corporate meddling?” is still extremely relevant today, as many of the issues faced by public schools — dwindling funds, lack of academic freedom, and widespread charter proliferation — have been greatly influenced by foundations. And the influence they wield is growing, despite a poor track record of previous reforms.

Of course, it should be noted that not all foundation grants come with insidious strings attached. CTA and NEA have foundations that do great, innovative work for our schools. And many other foundations also exist that have been exceptionally generous in providing money to schools in this country. But quite often corporate foundations are financing the fad of the moment, advancing a political agenda or attaching substantial strings to their generosity.

For the purposes of this feature, we’ve chosen to focus on the Broad, Bill and Melinda Gates, and Walton Family foundations — groups that are having increasing influence on education policy. The following stories revisit some of the schools we reported on in 2004 and explore the mounting impact of corporate foundations on public education. ❧

As government continues to take funding away from public education, schools increasingly put themselves in the hands of private foundations. It begs the question: Is society abdicating control of public education and embarking on a dangerous path?

Corporate foundations have been fighting for control of public schools for years in Oakland, Sacramento, Los Angeles and San Diego (see accompanying stories). Billionaires like Bill Gates, the Walton family and Eli Broad have quietly risen to power at both the state and federal levels, although their huge effect on education mandates and legislation is not yet on the radar screen of most people.

“The influence of these corporate foundations on schools is at the root of many of the problems we’re confronting today in public education,” observes CTA President David A. Sanchez. “Race to the Top is a prime example, as they try to bribe states to accept onetime dollars in exchange for sweeping policy changes. Strings are attached to federal funding in a way we’ve

never seen before — and at a time when our schools need more help than ever.”

The Bill and Melinda Gates Foundation spent millions of dollars this year to influence the way the federal government distributed \$5 billion in grants to “reform” public schools in Race to the Top (RTTT). The foundation offered \$250,000 to help states hire consultants to apply for RTTT money — but only if they embraced the same goals as the Gates Foundation: paying teachers based on student test scores; opening up charters that operate independently of local school boards; and agreeing to a common set of standards in every state.

In Round 1 of RTTT, 37 states applied. Gates offered assistance to 15 handpicked states; 10 of them, including Tennessee, were among the 16 finalists in Round 1. One *Washington Post* columnist compared their 30-minute presentations and Q&A sessions to the voting on the popular TV show *Project Runway*. U.S. Secretary of Education Arne Duncan found only two states — Tennessee and Delaware, states that worked with teachers on the application — deserving of money. The rest went home empty-handed.



Who’s pulling the strings?

The Eli and Edythe Broad Foundation has provided nearly **\$400 million** to school districts to open charter schools, implement unreasonable accountability measures, train superintendents in top-down management styles, and pay for the salaries of Broad associates working in school districts. Billionaire Eli Broad has also backed anti-union candidates in school board and state election races. He is the 42nd-richest person in the world, according to *Forbes*, and is a retired homebuilder and life insurance magnate.

The Bill and Melinda Gates Foundation has given over **\$1 billion** to education and is chaired by Bill Gates of Microsoft and his wife, Melinda. Gates’ tactics as founder of Microsoft have been called anti-competitive, but he has encouraged competitive tactics among schools in promoting Race to the Top applications and legislation. After his grants funding small schools proved ineffective, Gates set his sights on funding charters, implementing performance-based teacher pay programs, and firing “bad” teachers. Bill Gates was the world’s wealthiest man from 1995 to 2009, excluding 2008 when he ranked third.

The Walton Family Foundation is focused on “reforming” the country’s public education system by pumping money into school vouchers and charter schools. Since the late 1990s, the Waltons have been at the forefront of the charter school movement. Over the years, they have given **hundreds of millions** of dollars to various charter schools and ally organizations around the country. The Waltons are the founders of the ubiquitous Wal-Mart stores.

California didn't make it to the finalists, but was so desperate for RTTT money that legislators changed three laws they believed would increase eligibility. One removes a "statewide firewall" prohibiting the use of student test scores in evaluating teachers. The second was an open-enrollment measure that allows students in the lowest-performing schools to apply to other schools anywhere in the state, including in their own district. The third was a "parent trigger" provision, whereby 50 percent of the parents in a low-performing school could force districts to adopt a major reform plan, such as closing the school, firing the principal and up to half the teachers, or turning it into a charter.

"California didn't get any money, and now we are stuck with these bad laws and are struggling with how to implement them," says Sanchez.

California and most other states without Gates backing didn't fare much better in Round 2 of RTTT. According to *Education Week*, nine of the 12 winning applicants from a field of 47 states over two rounds of the RTTT competition were backed by Gates and given \$250,000 apiece to craft proposals that were in "good strategic alignment" with the foundation on key issues such as supporting charter school expansion and evaluating and compensating teachers based on test scores.

"The real secretary of education, the joke goes, is Bill Gates," states an Associated Press news analysis. However, it's not a laughing matter; Duncan's inner circle includes several individuals closely aligned with the Gates and Broad foundations. (See sidebar, page 13.)

Gates has denied that his foundation is a "partner" in the RTTT program but has this to say: "We're doing all kinds of experiments that are different. The Race to the Top is going to do many different ones. There's no group-think."

The U.S. shouldn't be experimenting on American children. They deserve proven reforms.

Experiments gone awry

In 2000, the Gates Foundation decided that small schools were the answer to

boosting graduation rates, so Gates pumped about \$2 billion into a campaign to restructure American high schools. This included 45 states and founding 2,600 schools with fewer than 400 students. Some of the schools were newly created and others were the result of dividing large, comprehensive high schools into smaller ones.

"Although foundation officials regularly claimed that their decision to support small schools was based on research, most of the research available at that time was written by advocates of small schools, so the foundation had no warning signs of the difficulties it would encounter in pursuing its agenda," writes Diane Ravitch, former assistant secretary of education, in her new book *The Death and Life of the Great American School System*.



Diane Ravitch

"The foundation seemed unaware of the disadvantages of small high schools, that is, schools with fewer than 400 students," writes Ravitch. "Because of their size, they seldom have enough students or teachers to offer advanced courses in mathematics and science electives, advanced placement courses, career and technical education, choir, band, sports teams and other programs that many teenagers want. Nor can most offer adequate support for English-language learners or students with special needs."

Gates admitted in 2009, "Many of the small schools that we invested in did not improve students' achievement in any significant way." Meanwhile, many school districts today are dealing with the fallout from Gates' failed experiments — including those in Oakland, San Diego, Sacramento and other areas. (See accompanying stories.)

Having given up on small schools, Gates set his sights on charter schools and, according to Ravitch, has supplied nearly \$100 million since 2000 to charter management organizations such as New Schools Venture Fund.

In 2008, after changing course, Gates

Running schools like a business doesn't work

Based on the belief that schools should be run as a business, billionaire Eli Broad has spent millions to train school administrators who have no experience in public education. The results have been disastrous for some Broad-trained leaders, causing disruptions in communities. A few examples:

> Deborah Sims, superintendent of the Antioch School District, was asked to resign in 2009 due to her top-down, abrasive style of management, in a campaign led by outraged members of the Antioch Education Association.

> In March 2009, the Capistrano School District terminated its superintendent, Arnold Woodrow Carter, for "material breach."

> In San Diego, Alan Bersin served as superintendent before being ousted by the San Diego Education Association and the community.

announced that in addition to funding charters, he planned to invest millions in performance-based pay programs for teachers, creating data systems, promoting national standards and tests, and finding ways for school districts to fire "ineffective" teachers. This put him on the same page as billionaire Eli Broad, who is also devoted to charters, merit pay for teachers, and the belief that schools should function as businesses — a philosophy also shared by the Walton family, of Wal-Mart stores.

The Obama administration and Duncan have embraced this philosophy, and Ravitch worries this will impact the future of education in America. Charters, she asserts, are creating a two-tiered system in urban districts, with charter schools for motivated students and public schools for the rest. They drain money from existing schools and cause teacher burnout. And judging teachers solely on test scores and paying them accordingly is unfair to both teachers

and students, Ravitch asserts.

While there are some outstanding charter schools, they are no magic bullet for success. The majority of the 5,000 or so charters nationwide appear to be no better, and in many cases worse, than local public schools when measured by achievement on standardized tests, according to experts citing years of research. Notes the *New York Times*, “Last year, one of the most comprehensive studies by researchers from Stanford University found fewer than one-fifth of charter schools nationally offered a better education than comparable local schools, almost half offered an equivalent education and more than a third, 37 percent, were significantly worse.”

Ravitch warns that the *real* agenda for corporate foundations and the “billionaire boys” behind them is the deregulation of schools, much like the deregulation of energy companies and health care.

“Deregulation contributed to the near collapse of our national economy in 2008, and there is no reason to anticipate that it will make education better for most children,” she says. “Removing public oversight will leave the education of our children to the whim of entrepreneurs and financiers.”

Foundations gaining momentum

Corporate foundations have gone from playing a supportive role in education to dictating unproven school “reforms.” The power they wield is growing.

Richard Rothstein, author of *Grading Education: Getting Accountability Right*, noted in a *New York Times* article that corporate donations may be acts of generosity, but also benefit the wealthy. Using a formula developed by Michael E. Porter, a professor at Harvard Business School, Rothstein estimates the government loses about \$4 in taxes for every \$10 a philanthropist donates.

If a corporation can afford to give money to a school district, it can afford to be taxed, asserts Joel Spring, author of *American School: From the Puritans to No Child Left Behind*. “However, most of the time foundation money is presented with a public relations spin, so people see it in a positive light.”

Foundations demand that public schools and teachers be held accountable for performance, but they are accountable to no one. They do not have to disclose the details of their spending, although the government does.

“It’s anti-democratic to relinquish control of public education to private foundations in ways that would never survive the scrutiny of voters,” says Sanchez.

Operating schools as businesses may sound

good on paper — but students are not widgets and schools aren’t expected to turn a profit.

“The corporate model of reform pays little heed to other expectations of public schools — building just and tolerant communities, reducing distrust of one another and our shared institutions, safeguarding democratic ethics and introducing children to the world,” warns Dorothy Shippy in an article titled “Corporate Influence.” “Neither markets nor business ethics routinely put equality or fairness above profits.”

Gates, Broad and the Walton family are not “experts” in education. They may be acting in the name of “school reform,” but they are pushing their own agendas and programs based on ideology rather than research.

“The judgment of donors is sometimes wiser than that of school officials and sometimes not,” says Rothstein. “But it is hard to separate good ideas from foundation proposals that, while seemingly attractive, may be passing fads or only a way to advertise a donor’s virtue.”

Instead of being scrutinized, corporate foundations are given deferential, “gentle” treatment by the media, who fear taking them on. They operate, says Ravitch, in a “conspiracy of silence.”

“I don’t think the public is aware of their influence on federal public policy

Sacramento schools under corporate control

In 2003, Sacramento High School became St. Hope Charter High School. At that time Kevin Johnson, a former basketball star with the Phoenix Suns, raised millions of dollars from several corporate foundations to make the conversion happen at his alma mater, including \$3 million from the Gates Foundation and more than \$1 million from the Walton Family Foundation.

Today, enrollment is dwindling and the school is in its third year of Program Improvement. It received a bronze medal from *U.S. News* for raising test scores, going from 719 to 731 on the API from 2008 to 2009, but has received criticism for “counseling out” students who are not successful. Some say the college-prep school is intent on only serving motivated students. Those who cause trouble are “shipped out” to other schools, say critics.

Johnson is now mayor of Sacramento, and St. Hope operates several charters in Sacramento. During the past year there was a scandal over allegations that the nonprofit association Johnson founded used federal money to pay volunteers for jobs including political activities, running personal errands and washing



Linda Tuttle
Sacramento City
Teachers Association

Johnson’s car. The terms of the settlement stated that St. Hope Academy must repay nearly \$424,000 in return for the government’s lifting its suspension on future federal grants. But corruption allegations are only part of the problem.

“The community is still angry about the closure of Sacramento High School because it was a comprehensive high school that offered students a broad selection of electives, sports and extracurricular activities,” says Linda Tuttle, president of the Sacramento City Teachers Association (SCTA). “The charter school is not a comprehensive high school. And it’s a bad state of affairs when a school can pick and choose its own students.”

Johnson recently started a new nonprofit,

for education,” says Sanchez. “We need to make the public aware of the influence of large corporations on policy-making at the state and national education levels. And CTA will continue to put pressure on both Arne Duncan and our legislators to keep them from further eroding all the good things that are going on in schools today. To do this, we have to stop accepting money with strings attached.”

State Sen. Gloria Romero (D-Los Angeles) was defeated in her bid for state superintendent of public instruction, despite being backed in the primary by Eli Broad, Netflix's founder Reed Hastings and other charter advocates affiliated with foundations. Romero was the driving force in passing flawed legislation that was supposed to make California's schools eligible to receive RTTT funding. In the June elections, the public sent a clear message: All of our schools and communities deserve quality, affordable education and should not have to compete for those rights.

According to *Sacramento Bee* columnist Peter Schrag, foundations are cutting back on their donations in California because of what they describe as a lack of leadership. However, foundations are still pouring millions into efforts to further their political agenda.

If there's any silver lining to the role

U.S. Secretary of Education
Arne Duncan's ties to
CORPORATE
 foundations

- > **Margot Rogers**, Duncan's former chief of staff, served as the special assistant to the director of education at the **Bill and Melinda Gates Foundation**. She resigned in June.
- > **Jim Shelton**, the assistant deputy secretary for innovation and improvement, manages the department's "competitive teacher quality," school choice and learning technology programs. He was a program director for the education division of the **Gates Foundation**.
- > **Joanne Weiss**, director, Race to the Top, oversaw research and operations of the New Schools Venture Funds before joining the White House. That pro-charter school group is backed by the **Broad Foundation**, the **Gates Foundation**, the **Walton Family Foundation** (Wal-Mart), and the **Doris and Donald Fisher Fund** (Gap stores), among others.
- > **Russlynn H. Ali**, assistant secretary for civil rights, served as an assistant director of policy and research at the **Broad Foundation**, for which she was also on loan as chief of staff to the president of the Los Angeles Unified School District Board of Education.
- > **Thelma Melendez de Santa Ana**, assistant secretary for elementary and secondary education, oversaw grants from the **Annenberg Foundation** and implemented schoolwide accountability reform in 15 Los Angeles County school districts.

foundations play in public education, says Schrag, its calling attention to the government's inadequate funding of public education.

“Maybe a few more whacks from people with big clubs and deep pockets will ultimately wake us up,” says Schrag.

“Maybe.” ✦

Stand Up for Sacramento Schools, funded in part with seed money from the Broad Foundation, to support new charter schools and create a report card to “grade” Sacramento schools.

The district's superintendent, Jonathan Raymond, was trained at The Broad Center's executive management training program and had no previous experience in education. Tuttle says it's been difficult to work with the top-down superintendent. After months of negotiations, SCTA recently settled with the district, and members accepted pay cuts and concessions to keep schools open.

“Our new superintendent smiles a lot. But it's like an invisible wall has gone up and the type of access we have always had is gone, after years of developing a good working relationship with the district. He absolutely views schools as a business — and we are feeling that.”

Sacramento schools are feeling a lack of academic freedom from millions of dollars donated by the Packard Foundation to



John York
 Sacramento City
 Teachers Association

pay for scripted learning. And the creation of small high schools with a \$4 million grant from the Bill and Melinda Gates Foundation in 2002 hasn't worked out ideally. Genesis High School will be closed, and others are struggling to keep up enrollment. Large, comprehensive high schools were also divided into small learning communities (SLCs) with Gates money, which has been a mixed bag, say SCTA members.

When John York came to teach at Kennedy High School, he was pleased to find strong camaraderie and support among colleagues in the English Department. “I was a new teacher, and if I had any questions, I could walk out in the hallway and find 100 years of experience on my floor from veteran teachers,” he recalls.

Teachers had been collaborating on ways to close the achievement gap with a new WASC plan (Western Association of Schools and Colleges' accreditation program) and were readying for implementation. But the new principal called a meeting to inform them that the Gates plan would

Continued on page 36

Oakland schools suffer from half-baked reforms

A line on the playground divides two Oakland schools — Reach Academy and Education for Change. Both schools share the site of what used to be Cox Elementary School.

Oakland Education Association (OEA) member Katherine Clarke-Hines, a teacher at Reach Academy, says the line is a really a division between haves and have-nots. It's difficult, she says, for those at her school to witness every day the advantages of those across the line at the charter school.

"At the charter school they have coaches for subject matter," says Clarke-Hines. "They have sports, they have manipulatives in their classrooms, their teachers have personal computers — and they also pick and choose their students."

Charters in Oakland created by corporate foundations have drained money from the district, says Betty Olson-Jones, OEA president, because they decrease attendance and per-pupil funding from mainstream schools while operating costs stay the same.

In Oakland, foundation money has also

been used to divide large schools into smaller schools. The combination of the small schools movement and charter school proliferation has had a negative impact on the urban district overall and should serve as a warning to others about accepting money with strings attached, says Olson-Jones.

Oakland has 32 charter schools that enroll 18 percent of the K-12 population. Most



Betty Olson-Jones
Oakland Education
Association

were funded by corporate foundations within the past decade and are non-union. The Eli Broad Foundation gave \$4.7 million to Aspire Public Schools, a Northern California charter company that has three schools in Oakland. The Walton Family Foundation also donated large sums to charter schools there. And New Schools Venture Fund — a nonprofit "venture philanthropy" funded by corporate

foundations — has also made hefty contributions to Oakland charters.

"The agenda of those creating charters is to further erode public education," asserts Manny Lopez, an OEA member who left Cox after the conversion to a non-union charter. "They talk about giving parents so-called options, but parents just want good neighborhood schools. And dividing schools into really small schools is not cost-effective either."

Twenty to 30 Oakland schools may be closed. Some are small schools created by the breakup of large schools from Gates Foundation funding. But the five-year Gates grants have dried up, and the schools are too expensive to continue operation, especially given the current state budget crisis.

Small schools translate into big costs, since each has its own administrators and support

staff, even if it shares a campus with other small schools. So now Oakland Unified School District (OUSD) is liable for "excessive administrative costs" to the state for 78 excess administrators and must pay fines.

Fremont High School was a large comprehensive high school in Oakland that was divided into four small schools in 2003. Paul Robeson School of Visual and Performing Arts, which hasn't been able to afford arts in quite some time, closed in June.

Craig Gordon, a social studies teacher at Robeson, said he was very unhappy at the top-down decision to see Fremont divided into smaller schools, but thought that if done right, it could benefit students. He added that many people confuse small schools with small class size, but some classes actually got larger, with fewer teachers at each school to teach each subject. Electives were reduced or eliminated due to the small teaching staff. Three of the small schools at Fremont still have AP classes, but Robeson

In LAUSD corporate

A year ago, Los Angeles Mayor Antonio Villaraigosa announced plans to push through a proposal to allow public charter school operators and other outside groups to bid for control of 50 new schools and hundreds of existing schools over several years. In a victory for teachers, labor and public education, the Los Angeles Unified board of education ultimately decided to hand over 29 out of 36 schools to teacher-led groups in the district.

Nonetheless, there are 161 charter schools in LAUSD, serving approximately 58,000 students in kindergarten through 12th grade. Nearly all of them are funded by private corporate money issued through foundation grants. And much of it comes from Eli Broad, a retired life insurance magnate and homebuilder who is a staunch believer that schools should be run like businesses.

In 2007, the Broad Foundation issued \$10 million in grants to the Alliance for College-Ready Public Schools to open 13 new charter schools. In 2008, Broad awarded \$23.3 million in grants to three charter school organizations: KIPP (Knowledge Is Power Program), Aspire Public Schools, and Pacific Charter School Development. These grants brought the total Broad Foundation investment



LEFT: Oakland Education Association member Katherine Clarke-Hines, a teacher at Reach Academy.



ABOVE: Manny Lopez, an Oakland Education Association member, at Jefferson School. **RIGHT:** Craig Gordon, a social studies teacher at Paul Robeson School in Fremont.

lost them as funding and staffs were cut. Some schools attracted high achievers and had better scores than others.

“It is a phony reform to distract people

and make them think that change is right around the corner — and now it’s on to the next game,” says Gordon.

The district spent a staggering \$82 million on consultants last year, says Olson-Jones. Money from the Gates and Broad foundations, the Dell Foundation, and the Rogers Family Foundation sponsored “Expect Success,” a project costing more than \$20 million, which mostly funded the reorganization of the District Office. The union was not involved in the plan.

OUSD, just freed from state takeover, had had three graduates from the Eli Broad Academy serving as state administrators. Vince Matthews, the most recent state administrator and Broad alum, still has veto power over the elected school board. Since 2003, nine other Broad associates have also held high-level district positions — and Broad has donated \$6 million to the district. Broad helped finance an expensive lobbying campaign to prevent the return of local con-



trol to Oakland schools.

“There is such a big push from Eli Broad and other billionaire philanthropists for testing, accountability, getting rid of ‘bad’ teachers and measuring teachers by student test scores,” says Olson-Jones. “They want schools to be run like businesses, even though businesses are failing left and right. If schools were banks, they would have been bailed out a long time ago.” ↘

foundations wield enormous power

in Los Angeles charters to \$56 million since 2000, serving 25,000 total students, according to *RedOrbit.com*, a Texas-based Internet news source.

Recently, Eli Broad donated \$10.5 million to the Green Dot charter schools organization that will go toward opening 21 new high school campuses and enrolling about one of every 10 high school students currently in LAUSD over the next several years.

“This trend for increasing charters is hurting teachers and kids,” according to a statement issued by United Teachers Los Angeles. “It’s creating a two-tiered educational system — one for the haves and one for the have-nots. Charters get the cream of the crop when it comes to kids because they are based on a lottery system that attracts parents who are the most motivated. These schools don’t have the same percentages of English learners or special education students. And when they have discipline problems, they send them back to the public schools because they can’t handle them.”

When the school board rebuffed the mayor’s plan it was a victory for educators, but pro-charter corporate foundations continue to wield tremendous power in LAUSD, where they are entrenched in top district

administrative positions.

John Deasy, a top official with the Bill and Melinda Gates Foundation, was hired in June as second in command of the district. As deputy superintendent, his contract calls for a starting salary of \$275,000 — \$25,000 more than Superintendent Ramon C. Cortines — according to the *Los Angeles Times*, and puts him in position as top candidate for superintendent within two years. At the Gates Foundation, he managed the process through which school districts and charter schools apply for grants to develop new teacher-evaluation methods that include linking instructors to student test scores, reports the *Times*.

Deasy’s position is paid for by LAUSD, but corporate foundation money is paying for other key staff positions within the district. Matt Hill manages the district’s reform initiative, which pushed for the mayor’s plan, and has a salary covered by the Broad Foundation. According to the *Times*, “The pay of more than a dozen others is funded by a nearly \$4.4 million grant from the Wasserman Foundation, a \$1.2 million grant from the Walton Family Foundation [founders of Wal-Mart] and smaller amounts from the Hewlett and Ford foundations.”

These employees and consultants are developing a new system to evaluate teachers and administrators and were brought on board after the district superintendent helped Broad develop an academy to train school district leaders.

Broad’s efforts to control the news media may strengthen his hold on schools. According to several reports, he has looked into purchasing the *Los Angeles Times*. Undoubtedly, he would use that as a vehicle to perpetuate the myth that schools are failing and should be governed by private industry.

“It certainly is worrisome and a cause for concern when you have non-educators in control of public education in the second-largest school district in the country,” says the UTLA statement. “They come in with preconceived notions, without the view from being in the classroom, and it’s very problematic.

“Foundations do some good, and given the right set of circumstances they can be good for public schools. But in a reasonable, sane world, why would anybody really choose a corporate entity to run public education, considering the worldwide economic straits the corporate world has gotten us into?” ↘

Small schools increase segregation in San Diego



LEFT: Ramon Orozco, a math teacher at LEADS High School in San Diego. **INSET:** Michele Wirth, a resource teacher at both the Science and Technology School and the International Studies School.

In 2004, San Diego High School was transformed from a large, comprehensive high school into six small high schools on one campus, each with 400 to 500 students. The break-up was accomplished with money from the Bill and Melinda Gates Foundation.

It wasn't cheap. Instead of one principal, there were six. The small school principals doubled the number of counselors to help them with their duties. Each principal also had a secretary, and the campus went from having two attendance clerks to six.

It was no surprise that when the money ran out, it was too costly to sustain. Talks are under way for "restructuring," and the discussion includes closing some of the small schools.

Breaking a large school into smaller

schools was supposed to be a novel approach, but some San Diego Education Association members believe the end result was an old practice known as "tracking," which segregates students by ability, separating those bound for college from those who are not.

Tom Waller, a history teacher in the School of Business, says administrators jumped at the money offered by Gates because the comprehensive high school was in year 4 of Program Improvement (PI), and restructuring into smaller schools pushed the "reset" button on PI. It may have staved off sanctions, but it increased segregation.

The International Studies School attracted the cream of the crop with its International Baccalaureate program. The

school scored 818 on the Academic Performance Index in 2009, and has fewer English learners and students with learning disabilities. LEADS (Learn, Explore, Achieve, Discover and Serve) and the Science and Technology schools attracted a mix of students.

The schools with the highest percentage of English learners and students with disabilities — the Media, Visual and Performing Arts School, the Business School, and the Communications Investigations in a Multicultural Atmosphere (CIMA) School — also have the lowest scores and are in years 3 and 4 of Program Improvement.

"Foundations are trying to coerce behavior because they want to see change," says Waller. "And schools are desperate and see it as a life preserver thrown at them. But it might be a life preserver with smallpox all over it."

"For some schools it worked; for some it didn't," says Michele Wirth, a resource teacher at both the Science and Technology School and the International Studies School. "Yes, we got to know the kids better and some kids became more motivated, but the downside was losing so many electives we used to offer, because there was no money. We lost auto shop and lots of vocational things."

Teachers at the better-performing schools are more enthusiastic about the small-schools experiment and worry about their schools closing.

"Overall, it's a better school environment at a small school than at a big school," says Rudy Shaffer, a science teach-



er at the Science and Technology School. “You can plan cross-curricular lessons and projects and teachers talk to each other about the kids. It does cost a little bit more; I know all of our small schools have not been successful.”

Ramon Orozco, a math teacher at LEADS, says a small school environment allows him to offer students individual attention. “I’ve seen it make a difference,” he says. “If we revert back to the way it was before, we will lose the progress we have made.”

Waller, whose school has the most challenging population, disagrees.

“I would have used the money differently,” he says. “I would have spent it on kids’ health and things like glasses or fixing their teeth. I would have used it to employ kids for jobs that would give them skills — or at least a work ethic. I would have used it for more vocational training for the 75 percent of our students not getting a college degree. And if I did spend it on small schools, I would have set up an ongoing revenue stream.” ❖

“Foundations are trying to coerce behavior because they want to see change. And schools are desperate and see it as a life preserver thrown at them. But it might be a life preserver with smallpox all over it.”

Tom Waller, San Diego Education Association



It's not
for you,
it's for him.

September is
**NEA LIFE
INSURANCE
AWARENESS
MONTH**

What would happen to your family if something happened to you? With adequate life insurance coverage, they would be able to maintain a secure and stable home. Yet, 86% of NEA members are underinsured, and many don't even know it. To address this issue, during September NEA Members Insurance Trust is offering a wealth of online resources, tools, and information — everything you need to know about protecting your family financially.

Test your Insurance IQ and you'll be eligible to win one of a hundred \$100 gift cards.* It's all at the NEW neamb.com.

NEA Members Insurance Trust[®]

**YOUR DEDICATION
DRIVES OURS**[®]

You may also contact us at 1-800-637-4636, Monday - Friday, 8 a.m. to 8 p.m. (or Saturday, 9 a.m. to 1 p.m.) ET.

*Promotion conducted between 9/1/10 and 10/15/10. Sponsor, Operator is NEA Members Insurance Trust. Offer open only to NEA members. For details and official rules, visit neamb.com. Odds of winning depend on number of eligible entries submitted. NO PURCHASE NECESSARY TO ENTER OR WIN. VOID WHERE PROHIBITED.

L1050910



Ray Galela
Music teacher, El Camino High School
South San Francisco Classroom Teachers Association

Principles of Classroom Management by James Levin and James F. Nolan is a nuts-and-bolts book that proved invaluable during Galela's first two years of teaching. He still refers to it from time to time, as he does *The Dreamkeepers: Successful Teachers of African American Children* (Gloria Ladson-Billings), a book where the experiences of eight successful teachers are told anecdotally and tied into research about education and teaching. The stories are about how teachers overcame problems in class: cultural differences, behavior and financial issues. "I found the book easy to relate to," he says. "While reading each of the stories, I envisioned myself in the classroom as a student and then as the teacher. I certainly learned a lot from this book, and the stories told by the teachers still inspire me to be a better teacher."



Becky Stephan and Sherri Prendergast
Paraprofessionals, El Rincon Elementary School
Association of Classified Employees, Culver City

Advice from this pair of paras: Begin the year with a clear understanding of the classroom rules and find out whether the teacher wants a support professional to be independent or follow exact directions. Some teachers want a more structured environment and others give a little bit of leeway, they explain. When expectations are clear, support professionals and teachers can bounce ideas off one another and be partners. They also have this advice: "Make sure to tell the kids how smart they are. They will start to believe it if someone tells them it is true." Some of their favorite websites are www.schoolexpress.com/spelling01.php, www.theteacherscafe.com, www.tlsbooks.com, and www.opencourtresources.com.

Back-to-school tips *for* members

Stories by **Sherry Posnick-Goodwin** • Photos by **Scott Buschman**

Want some ideas that won't clog your inbox, take tons of time or require meetings with your Professional Learning Community? We asked some CTA members to share their favorite tips, resources and strategies to help get your year off to a great start.

Brittney Richardson
 Teacher, Kelly Elementary School
 Compton Education Association



"Come in, come in, please come in and look around," she says on the first day of school, in an effort to make parents feel especially welcome in her classroom. She calls the first day of school a "celebration" where parents are greeted enthusiastically and informed that they are part of the "team" she'll be working with throughout the year. Parents are invited to visit anytime, read stories to students and help with activities. "This makes parents want to be involved in the classroom and feel comfortable with me," she explains. "I communicate with them regularly, so they don't feel I'm only contacting them when something is bad." Showing support for her students in non-school settings also wins her huge points. Occasionally she will show up for students' baseball or soccer games or even Bible school presentations. "Everyone gets very excited when I step outside of the school arena," she says. "Parents are very appreciative and realize that you really do care about their child, and they are more motivated to work with me in helping their child succeed." As a result, parents are more willing to spend time practicing math with their child. Richardson says she frequently refers parents to www.mathdrills.com.

Courtney Woods-Ziani
 Single-subject credential student (French), San Diego State University
 Student CTA



Photo courtesy of Courtney Woods-Ziani

Her favorite book for classroom management for middle and high school students is *The First Days of School* by Harry Wong. "The book is written in a practical user-manual style and has a corresponding website offering supplementary information." She uses www.blogger.com to create free class blogs where she posts homework assignments, extracurricular information, and any other tidbits she wants to share with students. "I use docstoc.com to transform document files into embed codes to post work on our class blogs. It's free. To make learning come alive, use multimedia — lots of music, live streaming, Internet, blog, iPhone apps — to keep learning current and integrate technology. You can teach two skills at the same time."

Tony Gonzales
 Science teacher, Merced High School
 Merced Unified High School District Teachers Association



Get to know your support staff, says Gonzales, or "the people that really run the school." This includes secretaries, custodians and others who can help improve your teaching environment. He also gets to know his students — their culture, interest and goals — by conducting student surveys at the beginning of the year. His questionnaire asks students about their hobbies and interests outside of school and future career plans. When he knows their interests, he can make his subject matter more relevant to their lives. For example, if a student is interested in medicine, questions in Gonzales' biology class might revolve around medical science. "Sometimes it's all the same concept, but it's worded differently to be interesting and relevant to different students."

Visit us online



To read more back-to-school tips by members for members, see the extended story at www.cta.org/schooltips.



Tiffany Samora
 English language arts and AVID teacher,
 Muscatel Middle School
 Rosemead Teachers Association



Debbie Todd
 Academic literature teacher, Kings
 Canyon Middle School
 Fresno Teachers Association



Jamal Cooks
 Assistant professor, secondary educa-
 tion, San Francisco State University
 California Faculty Association



Steve Aberle
 Spanish teacher, Computech
 Middle School
 Fresno Teachers Association

A lesson plan

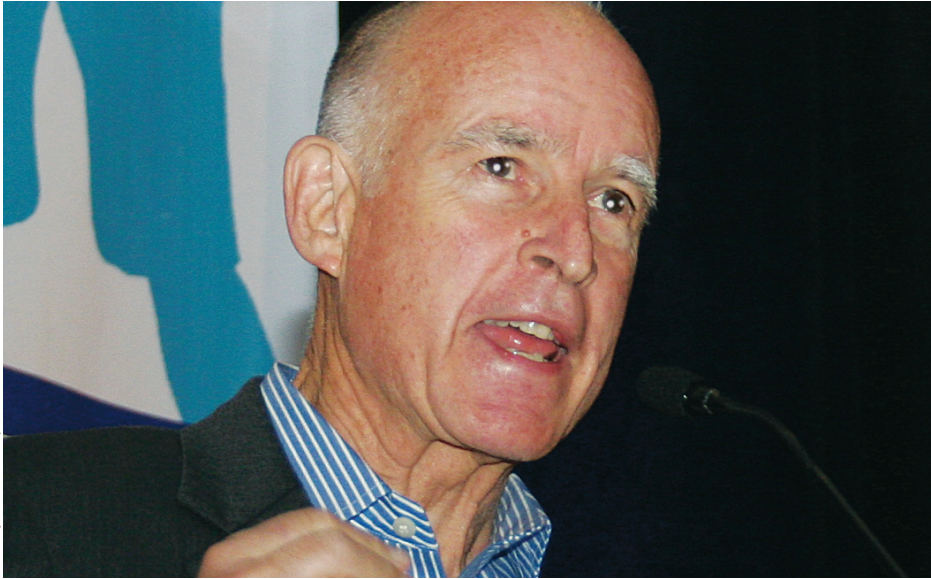

Photo by Dave Earl Carpenter

for victory

How we begin to put California back on track

Story by **Dave Earl Carpenter**

The national economy has been devastated and is slow to recover. Our state government is dysfunctional and can't seem to fix the broken tax structure that is crippling the state. And public education is under attack like never before. But with the upcoming November elections, California voters hold an incredible amount of power to make vast, positive change in the way our state funds public education.

Our current political leaders seem unconcerned about letting California — which boasts the eighth-largest economy in the world — plummet to

46th nationally in per-pupil spending. Current leaders want students to compete for money with federal programs like Race to the Top, and support foundations that blame everything on bad teachers. All this while large corporations receive massive tax breaks that total billions of dollars annually, allowing them to shirk their responsibility to the state and reducing funds for public education.

In November, electing pro-public education candidates — like Jerry Brown for governor and Tom Torlakson for state superintendent of public instruction — and passing Proposition 24, the Tax Fairness Act, will be key priorities for getting public education back where

it belongs, at the forefront of the discussion to revitalize California.

The CTA Board of Directors, with direction from State Council, has devised a plan to build organizational capacity in locals throughout the state. CTA's comprehensive plan lays the foundation for the major systematic tax changes that need to happen in California, and it lays the groundwork for CTA to pursue a tax initiative in 2012. The plan seeks to encourage all members to be a part of this important election and explains how all of the recommended candidates and initiatives are connected and are a strategic part of achieving the goal of making sure every student has a good neighborhood public school filled with quality educators, who are respected and supported (*see sidebar "CTA's plan for victory" on page 22*).

The plan will also provide CTA members with the tools they need to help energize this campaign by volunteering, using social media to spread the word, calling neighbors, family, colleagues and friends, posting stories about the difficulties faced in the classroom, and using every tool at their disposal to positively affect this election in favor of public education (*see sidebar "Social media play key role" on page 24*).

A governor with our values

Of utmost importance is the election of a California governor who shares our values about the necessity of good public education.

"We need a governor who will give educators a seat at the table, who will sit down with us to collaborate on the best solutions," says CTA President David A. Sanchez. "That someone is Jerry Brown. He will respect us, our opinions and our commitment to the profession."

Editor's note:

Look for the special "Election" issue of *California Educator* due out in early October.

Brown has shown that he is a friend to teachers and understands that public education is a right for students, not a privilege. He believes we must invest in our schools if we expect to create a brighter future for our state.

Brown's opponent, billionaire businesswomen Meg Whitman, is the antithesis of Brown. She wants to solve the state budget crisis by eliminating 40,000 jobs and further cutting the state budget. She wants to eliminate teachers' secure retirement system and put all public employees into risky 401(k)-style plans. These are ideas that are bad for our state and bad for our students.

"Whitman's wealth has helped her broadcast far and wide, with more than \$110 million spent so far on her campaign," says Sanchez. "But she has miscalculated if she thinks she can win this election in spite of, and on the backs of, California's working class."

Proposition 24

Public education in California has been repeatedly at the mercy of inefficient politics and the vagaries of the state's inadequate, unbalanced tax system. For decades, our state — a power-

house of innovation that once had the best education system in the country — has neglected its schools and students, denying them decent funding for education, choosing instead to enact unfair tax structures.



Photo by Scott Buschman

CTA's recommendation process

Question: Ever wonder what goes into CTA's process for recommending candidates?

Answer: A lot.

You might be surprised by how extensive and democratic (with a small d) the process for recommending candidates is.

"Our recommended candidates go through a vigorous vetting process that involves lots of checks and balances," explains Tim Sbranti, chair of the Political Involvement Committee of CTA's State Council of Education.

The process begins with a CTA member committee that conducts in-depth interviews with each candidate. All candidates for statewide offices are given the opportunity to submit a biographical form and answer an in-depth questionnaire that contains up to 20 questions having to do with issues specific to public education. Candidates identified by CTA as "friendly incumbents" do not have to go through the interview process again

unless the Board of Directors determines an interview is necessary — and there have been times when that occurs. This year, for example, several lawmakers were re-examined because of their support for Race to the Top legislation. Each state office has a different committee, comprising educators from small, medium, large, rural, suburban and urban chapters. The committee must approve a candidate by a 60 percent vote. And State Council must also approve by a 60 percent vote.

Once the committee makes a decision, a 30-day notice is sent to the local Service Center Council and local representatives, who then have a chance to appeal the recommendation to State Council.

"Committees themselves often have vigorous debates after the candidates have been interviewed," says Sbranti. "There have also been times when a committee has made a recommendation and that name gets pulled and changed on the floor of State Council."

The process for candidates recommended by local chapters is similar.

Following CTA's process, candidates for the seat are sent questionnaires and are invited to be interviewed by a committee of local leaders, which may include members from several chapters in that office's district. After answering a questionnaire, viable candidates go through personal interviews with the committee, which then makes a recommendation to their chapter presidents and their executive boards. If the recommendation wins 60 percent of the vote, it progresses to CTA's State Council for final approval.

"CTA's recommendation means a great deal to a candidate," says Sbranti. "It means you are supported by teachers in the largest teachers organization in the state. It's invaluable. Obviously, we make financial contributions to their campaign, but our reputation alone carries considerable weight. Also, CTA members themselves want to be able to make an informed decision about issues that are important to them, so they too rely on this process."

Dina Martin

Also known as the Tax Fairness Act, Prop. 24 ends nearly \$2 billion in special tax breaks for big corporations, loopholes that don't require the creation or protection of one single job in California (see related story "Prop. 24" on facing page). Virtually none of the tax breaks go to small businesses in our communities. This practice has had the effect of robbing billions of dollars from the state fund every year, and has been one of the major reasons why public education is currently in such a dire state.

"The November election can be the critical turning point that California needs to get back on track," says Sanchez. "We must act now to help stop the damage being done to our public schools and students, and see that large corporations pay their fair share to fund public programs."

Over the past two years, legislators cut more than \$17 billion from school funding, yet during the same period handed out tax breaks to large corporations and oil companies.

Tom Torlakson for state superintendent

Another priority for the November election is electing Tom Torlakson as state superintendent of public instruction. He is a candidate who has proved to have our students' best interest in mind.

Torlakson is a classroom educator with good ideas, as well as an active legislator who sponsored the CTA-backed Quality Education Investment Act — a bill that secured funding to bring extra resources to hundreds of lower-performing public schools. Torlakson fought to increase funding for textbooks and technology. He will be an advocate for educators and students, and he will fight to help all schools get the funding they need.

CTA's slate of recommendations for the November election includes passing Proposition 25, a common-

sense solution to California's chronic budget problems that would break legislative gridlock by allowing a simple majority of legislators to approve the state budget — just like in 47 other states — instead of letting a small minority of legislators hold it captive.

There's no disputing that a well-educated population is an important ingredient for a state's growth and future success. To give citizens a proper public education is to give them options for future prosperity, which in turn stimulate the growth of the state as a whole. Funding schools is the wisest investment California can make.

During this election we need to remember that students have a right to receive a quality education. This is what we fight for every day. And it's a fight we can win by staying focused and working together. ❖



Photo courtesy of Torlakson for SPI campaign

Tom Torlakson

CTA's plan for victory

Along with being members of the community most likely to vote, teachers are also among the group most likely to *get out the vote* — and that's exactly what CTA's Board of Directors was counting on when it approved the "Lesson Plan for Victory," which sets forth a comprehensive campaign plan for the November election.

"With so much at stake, it is critical for our members to get involved in this campaign," says CTA President David A. Sanchez. "Our priorities include electing Jerry Brown for governor and Tom Torlakson for superintendent of public instruction, and passing the CTA-sponsored Prop. 24, the Tax Fairness Act. We will be doing everything we can to make sure that public education wins at the polls."

More than the average voter, CTA members have witnessed the impact that budget cuts have had on California schools. In the past two years, they've seen what the loss of \$17 billion to education looks like: Class sizes have in-

creased dramatically; art, music, physical education, athletics, and counseling programs have been eliminated from many schools; and more than 32,000 educators have lost their jobs.

"Our goal is to make sure every student has a good neighborhood public school filled with quality educators, who are respected and supported," says Sanchez. "This is what we fight for every day. And it's a fight we can win by staying focused and working together."

Electing CTA-recommended candidates and passing Prop. 24 to repeal corporate tax loopholes will not only have a tangible effect on the future of public education, but will set the stage to pursue a new funding initiative in 2012.

"All of these candidates and initiatives are connected, and a strategic part of achieving our long-term goals," says Sanchez. "November's election will be the critical turning point our state needs to get back on track."

Between now and November, CTA members will have the opportunity to get involved in a variety of ways in the campaign. Many chapters will opt to reach out to friends, neighbors and supportive voters through area phone banks. Members will also be given election materials they can use to reach out to their colleagues and make sure they have the facts about the candidates and issues.

Election materials are already posted on CTA's website, www.cta.org, as well as on www.standupforschools.org, and more will be forthcoming as the campaign gears up. Included in the material are a voter guide, fact sheets, fliers and guides to conduct campaign meetings.

CTA is also using social media for this campaign. Members can keep up to date with the 2010 campaign by texting "CTAVOTES" to 69866 (be sure to include your name and ZIP code) and by e-mailing 2010campaign@cta.org.

Dina Martin

Prop. 24



Ensuring that large corporations pay their fair share

written by Sherry Posnick-Goodwin

The Bureau of Economic Analysis recently reported that U.S. corporations are sitting on \$1.6 trillion in cash reserves, a record amount. As a percentage of companies' total market capitalization, it's more than double the ratio seen before the economic crisis hit. The money, notes the report, is being "hoarded" and is not being used to create new jobs.

Nonetheless, California legislators granted corporations a huge tax break last year. At

the same time, legislators raised taxes for middle-class Californians by 18 percent.

But taxpayers aren't the only ones who lost out on the deal. Thousands of teaching positions were eliminated, and for students heading back to school, there are overcrowded classrooms, fewer instructional days due to furloughs, and shortages of basic supplies like paper and pencils. The corporate tax breaks, called a "dead of night deal" by the *Sacramento Bee*, were made without hearings and public testimony. They don't even require the creation or protection of one single job in California.

The good news, however, is that voters can repeal the tax breaks before they are scheduled to take effect next year by passing Proposition 24 — the Tax Fairness Act — in the November election.

Prop. 24, sponsored by CTA, would end \$1.3 billion in special tax breaks for big corporations. Those funds will

help keep the state from making deeper cuts to public education, health care and public safety.

If Prop. 24 passes, it will ensure that a few big corporations pay their fair share of state taxes by repealing three special corporate tax loopholes that were slipped into budget deals last September and again in February

These tax breaks unfairly benefit less than 2 percent of California's businesses, and they are the state's wealthiest multistate and multinational corporations.

behind closed doors. These loopholes, slated to go into effect in 2011, allow corporations to get refunds for taxes in past years by writing off new losses; get tax credits for things like research and development, and cash those credits in to reduce taxes on profits that have nothing to do with these efforts; and use a lower sales-based income formula to reduce taxes, for corporations that do business in other states.

The *Bee* offers a scenario of how some companies might benefit: "The breaks would be sweet. Say a company has two good years. It pays taxes, and the state spends the money. Then, say the company loses money. It could use that loss to get a refund on the taxes it paid in the two previous years. The break, amounting to \$500 million annually, would force the state to essentially grant retroactive tax refunds."

The big corporations that are paying to defeat Prop. 24 and keep these

loopholes paid their CEOs more than \$8.5 billion in the last few years, and made more than \$65 billion in profits last year, while at the same time laying off more than 100,000 workers. Meanwhile, during last year's budget disaster, the Legislature made \$30 billion in cuts that resulted in 16,000 teacher layoffs, hiked college tuition for students, and put 6,500 prisoners back on the street.

CTA President David A. Sanchez notes that corporate taxes accounted for 15.4 percent of the general revenue collected by California in 1976. "By 2014, after the breaks take hold, corporations would only account for 9.4 percent of tax collections," says Sanchez. "To say this would hurt businesses is misleading, because 98 percent of California's

businesses — especially small businesses — would get virtually no benefit from the tax breaks. These tax breaks unfairly benefit less than 2 per-

If Prop. 24 passes, it would repeal loopholes that allow corporations to:

- > Get refunds for taxes in past years by writing off new losses.
- > Get tax credits for things like research and development, and cash those credits in to reduce taxes on profits that have nothing to do with these efforts.
- > Use a lower sales-based income formula to reduce taxes, for corporations that do business in other states.

cent of California's businesses, and they are the state's wealthiest multi-state and multinational corporations."

"Proposition 24 doesn't hurt Cali-

fornia's small businesses," adds Sanchez. "It ensures tax fairness, so that big corporations have to play by the same rules as the rest of us."

Social media play key role

The use of social media — including Facebook, YouTube, Twitter and even text messaging — has played a key role in election campaigns, most notably in the election of President Barack Obama in 2008. And with the November election around the corner, CTA members have already begun using social media to get the word out about important candidates and issues.

"We are hoping our members will get on the social media bandwagon in our campaign to elect Jerry Brown as governor and Tom Torlakson as superintendent of public instruction and to pass Prop. 24, to close corporate tax loopholes," says CTA Board member Jim Groth. "Right now, they can text 'CTAVOTES' to 69866 to get the latest campaign updates and find out ways to get involved."

Members can also receive targeted e-mails from the campaign by e-mailing 2010campaign@cta.org, make use of CTA's Facebook page, and obtain helpful materials from several websites, including www.cta.org and www.standupforschools.org.

CTA used some of these social media tools in its Pink Friday campaign in March 2009, and again this year in its March 4 statewide actions. The November election will provide a chance to build on and expand the use of these tools.

CTA members most recently helped the National Education Association lobby Congress to pass the Education Jobs Bill, which will save the jobs of an estimated 161,000 educators nationwide. That campaign was carried off largely through text messaging and e-mails to the U.S. Senate. Supporters

Continued on page 36

"Speaking of fairness," comments Jean Ross, executive director of the California Budget Project, a nonprofit that advocates for low- and moderate-income taxpayers, "these tax cuts were slipped into budget deals at the last minute, with no public input, during the worst budget crisis in the state's history. In a transparent and open process, they never would become law."

The \$1.3 billion in tax breaks to wealthy corporations could be used for better purposes, such as reducing class size in California schools, buying new textbooks for students, and allowing more students to attend college, as well as providing health care to low-income children and seniors. ❖

For more information about The Tax Fairness Act, visit www.yesprop24.org. To learn how you can become involved in this important campaign, visit www.yesprop24.org/getinvolved.

Programs for California Professionals in Education Designed to Advance Your Career



Call toll free at 877-GO-TO-ULV
degreeinfo@laverne.edu | laverne.edu

Credentials and Certificates

- Multiple and Single Subject
- Administrative Credentials
- CTEL
- Education Counseling
- School Psychology
- Special Education
- Reading and Language Arts
- Child Life Specialist

Bachelors

- Liberal Studies
- Child Development

Masters

- Educational Management
- School Counseling
- Special Education: Mild/Moderate
- School Psychology
- Reading
- Special Emphasis
- Child Life
- Child Development
- Advanced Teaching

Doctoral

- Organizational Leadership (Ed.D.)



- Small classes with active faculty
- Programs throughout California
- Flexible scheduling
- CCTC approved and WASC accredited

UNIVERSITY OF LA VERNE
College of Education and Organizational Leadership
1950 Third Street, La Verne, California 91750

One of
**America's
Best Colleges**
Forbes Magazine

Officially endorsed by 

Good News!

Auto insurance rates are reduced by an additional **11.7%** for CTA members.

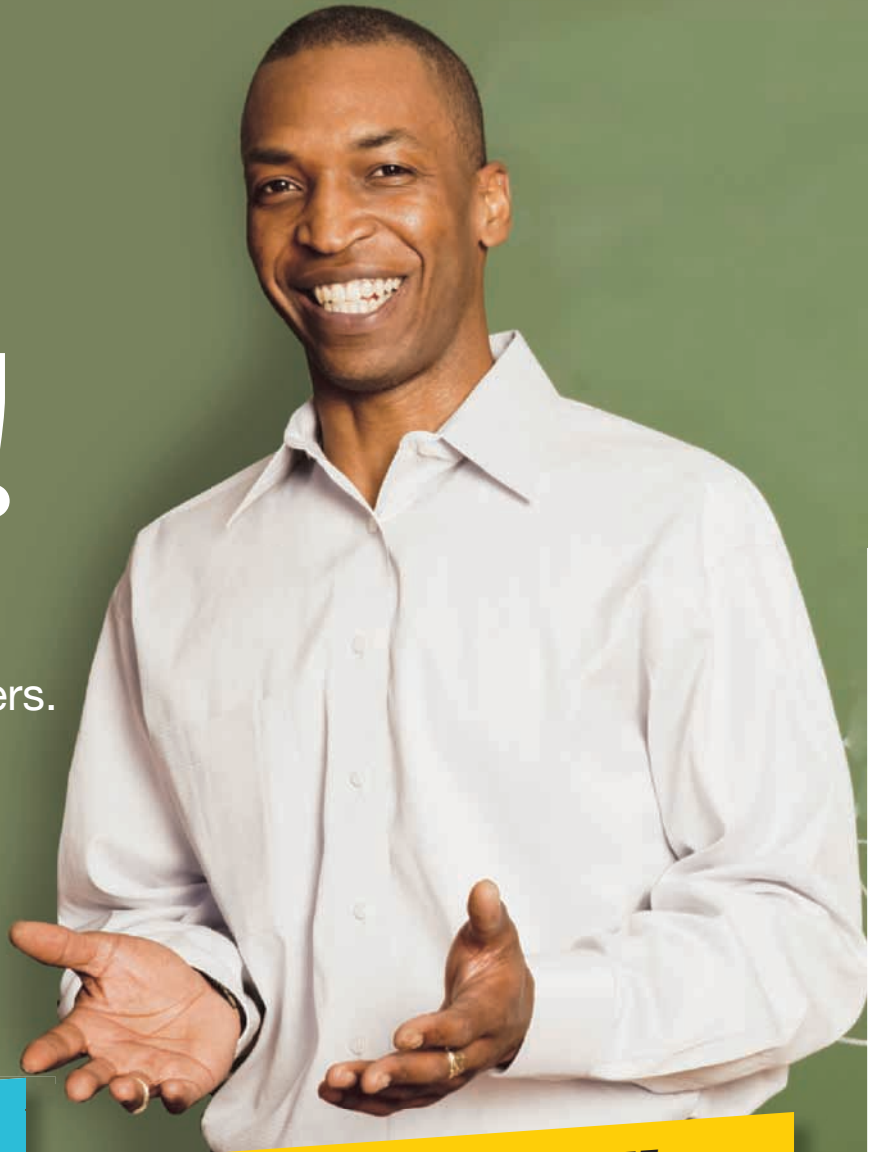

NEW LOWER RATES!

CALL 1.888.744.9717 TODAY FOR A FREE, NO OBLIGATION QUOTE.



Have you received an auto insurance quote from California Casualty before? Now's the time to get a new quote. Rates for CTA members have just been reduced by an additional 11.7% on average, so call now to find out how much you can save. California Casualty has been proud to serve CTA for nearly 60 years with innovative auto and home insurance. Now, we're happy to offer you that same great coverage for less money. Just call 1.888.744.9717 or visit www.calcas.com/cta today!

*Rates for current CTA policyholders will be adjusted at renewal.

OR GET A QUOTE ONLINE AT WWW.CALCAS.COM/CTA



Presidents Conference focuses on upcoming elections

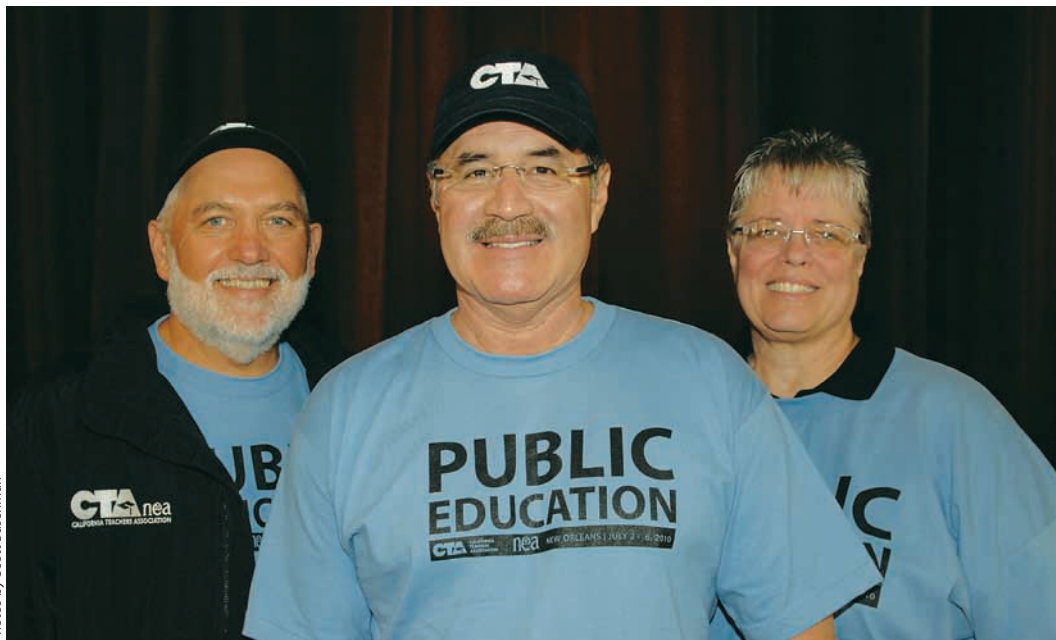

Photos by Scott Buschman

LEFT: CTA Vice President Dean Vogel, President David A. Sanchez, and Secretary-Treasurer Gail Mendes at the Presidents Conference in July, where CTA chapter leaders focused on the upcoming election.

RIGHT: Association of Coronado Teachers President Katie O’Keefe and Beaumont Teachers Association Vice President Norman Ault.

“This election is really, really important,” said Pablo Martin, MiraCosta College Teachers Association president, at this year’s Presidents Conference in Asilomar, which focused largely on the upcoming November election. “People are going to have to stand up for what’s right. We have big corporations, think tanks and ultraconservative groups putting out information that isn’t real. We need to reach out, especially to young people, and get everyone actively engaged.”

“November’s election can be the critical turning point our state needs to get back on track,” said CTA President David A. Sanchez in his welcome

ing speech. “It’s imperative that we have a governor who shares our values about public education. Keeping our members informed and engaged for November is going to be critical, and we must talk with our friends and families about the real threat of Meg Whitman not only to California schools but to our entire state.”

Chapter leaders said they

are ready for an education-friendly governor, as well as other candidates and measures that are critical to the survival of public education in California.

“Absolutely there’s a sense of urgency,” said Jim Grijalva, president of the Los Altos Teachers Association. “I’ve been wearing black since March 13. The death of public

education is imminent unless we do something.”

Proposition 25 is a solution to California’s budget disaster, added Grijalva, because it breaks the legislative gridlock by allowing a simple majority of legislators to approve a state budget rather than a two-thirds supermajority.

“The way things are now, one ‘no’ vote counts as two votes,” he added. “We need something better than that.”

“We have to elect Tom Torlakson,” asserted Linda Hansen, Napa Valley Education Association president. “He’s one of us. He’s been a teacher. He’s been involved in all the



RIGHT: Chapter leaders and CTA Board members show their solidarity in support of public education.



things we do and knows what is important in educating our children. My chapter will be doing a lot of community outreach and getting information out to our community about how important this is.”

Lewis Lester, Orange County Schools Education Association bargaining chair, said his chapter is starting a political action committee to organize members politically in his community, which leans toward conservatism.

“Education is more important today and more at risk than it has been in the last 30 years,” said Lester. “Taxpayers need to do something different, and they haven’t done anything different since Proposition 13. Proposition 98 was supposed to be a floor, but it is now a ceiling.”

It is imperative, he added, to pass Proposition 24, the CTA-

sponsored Tax Fairness Act, which eliminates nearly \$2 billion in tax loopholes for corporations.

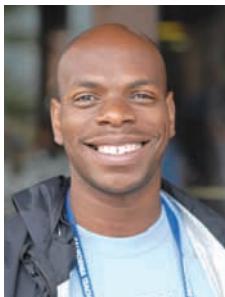

Lewis Lester
Orange County Schools Education Association

Laura Williams, president of the Teachers Association of Norwalk, said that it would be an injustice to allow big money from corporations and billionaires to buy the election in California.

“I believe spending all that money will backfire on Meg Whitman,” said Williams. “The working-class people don’t appreciate being manipulated. I am going to organize phone banking and be very politically active to stop her.”



Laura Williams
Teachers Association of Norwalk

Keith Law, president of the Merced College Faculty Association, said he plans to combine tactics so that association members working to elect an education-friendly school board can also work on statewide campaigns.

SHERRY POSNICK-GOODWIN

CHECK OUT WHAT'S NEW AT **CTAinvest.org**

Need help with your 403(b)?
Have questions about investing and retirement planning?

CTAinvest.org has answers.



1 Getting Started

This section will step you through how to get started with your 403(b) or 457 plan.

2 Educational Videos

Topics include *Why Participate in Your 403(b)/457 Plan*, *Comparing 403(b) and 457 Plans*, *Choosing a 403(b) or 457 Product*, *A Look at Target-Date Funds* and *A Look at Fixed Annuities*.

3 Ask the Advisor

Post your general questions about financial issues. A team of financial experts will respond to the questions and post the answers for all to view.

4 Personalized Checklist

Download a list of financial planning duties and keep track of what you need to do to stay on course. You can even sign up for e-mail reminders!

No login is required!

Institute for Teaching gives Mini Grants

The CTA Institute for Teaching (IFT) has selected 12 recipients — four local chapters and eight CTA members — for the inaugural

IFT Mini Grant program, which supports strength-based, teacher-driven reform that improves the conditions of teaching and learning. The awards, ranging from \$4,000 to \$20,000, are for the 2010-11 school year. IFT received 49 grant applications, with requests totaling more than \$400,000.

BLACK OAK MINE TEACHERS ASSOCIATION, \$19,440. This project is a teacher-driven design to innovate and support two program changes for Northside School and for the district at large. Funds from this grant would provide training in Highly Effective Teaching and support collaborative time for teachers through professional learning communities. This project arose from a collective recognition that change must no longer be driven by external forces, but must come from within. The grant will support the belief of the school staff that a school culture should be inclusive of its community and stakeholders, be totally site-based, and be governed with informed, participatory decision making.

MT. DIABLO EDUCATION ASSOCIATION, \$5,000. This project will allow the chapter to investigate the possibility of creating a dependent charter school in partnership

with the Mt. Diablo Unified School District. The developmental process would be based on the belief that the school should be intellectually safe and respectful; distribute both authority and responsibility; maintain high expectations and the means to attain them. Consistent with a strength-based approach, the staff should regard students as capable and participatory beings, rich in both individual and social potential. The grant will fund first-year activities, specifically to explore community engagement and readiness for the development of a new charter school.

SWEETWATER EDUCATION ASSOCIATION, \$8,200. This project is designed to develop a comprehensive literacy and technology curriculum at Sweetwater High School for use districtwide, modeled on the national Computer Science Teachers Association's K-12 model currently in use throughout the U.S. The grant, which will fund the first year of what is designed as a three-year program, will enable the program coordinator to create a core team of six qualified classroom teachers to determine and drive a curriculum guide for grades 7-12 that would allow all district schools to offer a variety of technical courses.

TEACHERS ASSOCIATION OF NORWALK-LA MIRADA, \$20,000. This project works to create an affirmative career technical education/career pathway "school within a school" program at La

Mirada High School. The program will prepare at-risk high school students in grades 9-11 to join postsecondary programs in environmental majors, which lead to an industry-recognized certificate, licensure, associate or baccalaureate degree, and ultimately success in the "green economy." The grant will support teacher in-service, science lab equipment and field trips.

BRIAN BARTLETT (REDLANDS), \$3,956. This project will support the Pre-Engineering and Design course at Redlands High School by providing materials for four specific engineering units: mechanical, structural, aeronautical and environmental. These units actively engage students in research-based engineering design projects that incorporate problem-based learning, cooperative groups, and measurable outcomes. Student talents and strengths will be emphasized. Students will identify with the relevancy of their work and how it directly relates to a current need in our society.

KARINA CURIEL (GONZALES), \$4,000. This project will provide teachers at La Gloria Elementary School with a campuswide character education program. WiseSkills is a teacher-friendly curriculum that integrates character education into all subject areas. The program provides teachers the forum to highlight and model the Six Pillars of Character (respect, citizenship, caring, trustworthiness, fairness,

and responsibility). The program is consistent with IFT's Culture of Success program. The school wants an approach that focuses on positive character attributes and behaviors in order to alter a school culture that has produced increasing levels of bullying, name calling, fighting and harassment.

RICHARD PENNA (REDLANDS), \$5,000. This school/community project would support Cope Middle School's curriculum-aligned school garden master plan that has, since 2003, brought together various departments, administrators, parents and community volunteers. The grant would enable a new Gardening and Building class to purchase materials to promote practical skills, creativity and hands-on learning. Because the school's goal is to increase daily attendance and decrease tardiness, students who have exhibited poor attendance will be invited to apply for admittance.

DOUGLAS REDMAN (COLLEGE OF THE DESERT), \$5,000. This strength-based project involves community college automotive students in the creation of a training module. The grant will provide for the purchase of a front end clip from a late model vehicle from an auto recycler. Students will build it into a training module that will be used by every automotive instructor at the college. By building their own training module, both teachers and students will be

Continued on page 33

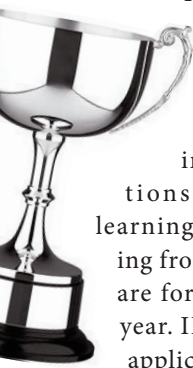

NEA Foundation awards 10 grants to California educators

This year, California teachers have received 10 grants from the NEA Foundation, which awards about 200 grants annually to educators nationwide in support of new ideas and practices to strengthen teaching and learning.

DONNA MARKEY and **JAMIE HAGEN-HOLT** of **VISTA MAGNET MIDDLE SCHOOL** in Vista received a \$5,000 Student Achievement Grant (in partnership with Nickelodeon) for an environmental project. Through this grant students will analyze the construction of one of the largest desalination plants in the world.

ALEX PICAZO and **REBECCA SOCO** of **RANCHO DEL REY MIDDLE SCHOOL** in Chula Vista received a \$5,000 Student Achievement Grant (in partnership with Nickelodeon) for a service learning project to promote literacy and ecological awareness. Struggling readers will be paired with motivated readers to read a novel about planting organic gardens. After reading the novel, students will plant their own organic school garden and participate in an art project promoting environmental literacy.

GIAN MICHAEL SARABIA and **ADRIENNE JERMAN** of **BORONDA MEADOWS ELEMENTARY SCHOOL** in Salinas received a \$5,000 Student Achievement Grant (in partnership with Nickelodeon) to teach students about sustainable farming methods by building an organic garden.

In addition to taking field trips to places that teach sustainable methods of organic farming, the students will create a webpage containing videos and photos that will explain the dangers of pesticide use and the benefits of sustainable farming.

LINDA PREMINGER and **MALIK DOHRN** of **WASHINGTON MANOR MIDDLE SCHOOL** in San Lorenzo received a \$5,000 Student Achievement Grant (in partnership with Nickelodeon) to lead a series of field trips designed to help students experience the relationship between human habitations in the local watershed and changes in the San Francisco Bay. Students will learn the importance of the interaction between water, topography, and human activity.

JESSIKA NEGRETE AGUSTIN and **MIKAKO FISHER** of **ELK GROVE UNIFIED SCHOOL DISTRICT** in Sacramento received a \$5,000 Learning and Leadership Grant to increase the proficiency of English language learners within the school district. Through this grant, a team of educators will identify schools in Northern California that have been successful in assisting ELL students to read at grade level. The team will target the most effective teaching practices and implement them districtwide.

ANNA MORAGA of **WILL ROGERS ELEMENTARY SCHOOL** in Ventura received a \$2,000 Learning and Lead-

ership Grant to attend the five-day Summer Writing Institute at Columbia University's Teachers College Reading and Writing Project. Upon completion of the institute, Moraga will share the teaching tools that she has learned with her colleagues and provide support for third- through fifth-grade teachers at her school, where writers' workshops will be implemented.

DEANN KARL and **BEVERLY RUBY** of **WESTSIDE ELEMENTARY SCHOOL** in Rio Linda received a \$5,000 Learning and Leadership Grant to establish a professional learning community to implement strategies to improve the achievement of English language learners and Hispanic students, focusing on the Guided Language Acquisition Development (GLAD) model of professional development in the area of language acquisition and literacy.

FRANCISCO JIMENEZ of **ASCOT AVENUE ELEMENTARY SCHOOL** in Los Angeles received a \$2,000 Learning and Leadership Grant to attend a weeklong reading conference at Columbia University to learn strategies that enhance student reading skills and the mechanics involved in establishing meaningful independent and partner reading.

KATHERINE WILLIAMS and **STEVE HOFFMAN** of **MIDDLE COLLEGE HIGH SCHOOL** in San Pablo received a \$5,000 Student

Achievement Grant (in partnership with Staples Foundation for Learning) to create a schoolwide water conservation and preservation program. As a member of a national consortium of water conserving high schools across the United States, the school will use funds to share the work that students have done in the community to raise awareness of water conservation with other schools.

JACKIE FERREIRA and **TARA HIGASHINO** of **UNION HOUSE ELEMENTARY SCHOOL** in Sacramento received a \$5,000 Learning and Leadership Grant to create a math and science website working with a team of K-6 educators. The interactive website will include online tools, document sharing, Web-based activities, and video streaming. The goal is to help students excel in California math and science content standards.

Since 1999, the NEA Foundation has funded more than 2,000 individual grants. Awardees are selected in three rounds throughout the year. The deadline to apply for the next round of grants is Oct. 15. Educators can now apply for grants on the NEA Foundation website at www.neafoundation.org.





Ceres educators settle contract, gain support

In the wake of a three-day strike by Capistrano teachers in Southern California, teachers in the Central Valley town of Ceres began to organize and mobilize to fight off a similar threat by their district to impose a contract with an 8.5 percent permanent salary cut.

As a result of their effort, they not only obtained a settlement in their favor, but became a stronger chapter in the process.

"This whole thing has done more to improve support for our chapter than anything we've done," says Cheryl Brewer, president of the Ceres Unified Teachers Association (CUTA). "And we're going to continue. We are going to turn our Crisis Committee into an Organizing Committee."

About 70 percent of the nearly 600 members participated in some sort of action this spring,

BELOW: Seventy percent of CUTA's 600 members show up to walk the line for a new contract.



which included several rallies, writing letters to the editor, attending board meetings, and taking part in planning activities.

"I got hundreds of supportive e-mails through this process. I even had a group of people who were 'Prayer Warriors' and would let me know they were sending out their prayers to me," Brewer says.

After going without a contract for almost 700 days, CUTA members became particularly incensed when the district threatened to impose a settlement that would require teachers to accept an 8.5 percent cut in pay. Even more galling was the fact that the superintendent had received a \$3,000 raise, an additional week of paid vacation and five fewer work days. Meanwhile, other administrators continued to receive car allowances, expense accounts and trips paid for by taxpayers.

"The district's threat to impose a contract not only disrespected the negotiating process,



Photos courtesy of CUTA

it insulted the teachers who are committed to our students. We've said it over and over again: To maintain a quality education for students in this district, it is important to invest in teachers," Brewer says.

A report by the independent fact-finding panel in June bolstered the teachers' position, and a settlement was reached shortly after. The chapter agreed to an 8.5 percent salary decrease in 2010-11, lowered to a 7.5 percent decrease in the following year. The contract also cuts five non-instructional workdays un-

ABOVE: Ceres Unified Teachers Association members on a three-day strike for a new contract.

til salaries are restored. Class sizes will also be held down, allowing only one additional student per class in 2011-12 and again in 2012-13.

"No one is thrilled, but it is better than what was offered and what would have been imposed, and the fact that the cut is not permanent makes it easier," Brewer says.

DINA MARTIN



Are you teaching
more **SPECIAL**
EDUCATION
students?

Have there been changes in how students with disabilities are being instructed at your school?

Are you a general educator being asked to provide instruction to more students with IEPs?

 **CTA WANTS TO HELP!**

- CTA is collecting information from both regular education and special education members about changes (if any) at your school site and in your district in how students with disabilities are being provided special education instruction and services. Let us hear from you!
- CTA has received a flood of questions from educators about changes in how students with disabilities are being provided appropriate special education instruction. Recent changes have raised serious concerns for educators about caseload, class sizes, lack of time to provide services to students, increased workload, and lack of involvement in the planning process.
- CTA will use an online survey to collect information from association members about the changes in how students with disabilities are being provided special education instruction. The information collected will be used to identify the scope of the challenge and help staff provide expedient assistance to local leadership and staff.

Let us hear from you! CTA staff and leadership encourage members to take this online survey by **Nov. 1, 2010**, at www.surveymonkey.com/s/specialedservicedelivery.

You are **1** degree of separation from changing your world. Which **1** will it be?

76 affordable degrees of distinction -100% online, including:

- M.Ed., Teaching - Instructional Leadership (K-12)
- M.Ed., Teaching - Special Education
- Master of Public Health
- M.Ed., Teaching - Elementary Reading *
- M.Ed., Teaching - English Language Learners*
- M.Ed., Teaching - Curriculum & Instruction for Elementary Teachers*

*Enrollment opens September 1, 2010

8 and 16 week graduate level courses start monthly at only \$300 per semester hour.



2009 Ralph E. Gomory Award for Quality Online Education

Let us help you get started today.

1.877.777.9081
studyatAPU.com/education



Respected. Affordable. Online.



Enjoy the rewards.



Get something back for your everyday purchases. Use your California Teachers Association Visa® Card with WorldPoints® rewards from Bank of America, and you'll earn points you can redeem for cash, travel, merchandise, even unique adventures.† Rewards for the things you buy anyway. Plus ongoing support for the California Teachers Association.

1.866.438.6262

Use Priority Code FACBGV when calling.

WorldPoints 

For information about the rates, fees, and other costs and benefits associated with the use of this Rewards card, or to apply, call the toll free number above, or write to P.O. Box 15020, Wilmington, DE 19850.

† Terms apply to program features and Credit Card account benefits. For more information about the program, visit bankofamerica.com/worldpoints. Details accompany new account materials.

This credit card program is issued and administered by FIA Card Services, N.A. The WorldPoints program is managed in part by independent third parties, including a travel agency registered to do business in California (Reg. No. 2036509-50); Ohio (Reg. No. 87890286); Washington (6011237430) and other states, as required. Visa is a registered trademark of Visa International Service Association, and is used by the issuer pursuant to license from Visa U.S.A. Inc. WorldPoints, the WorldPoints design and Platinum Plus are registered trademarks of FIA Card Services, N.A. Bank of America and the Bank of America logo are registered trademarks of Bank of America Corporation. All other company and product names and logos are the property of others and their use does not imply endorsement of, or an association with, the WorldPoints program.

©2008 Bank of America Corporation

T-709149-092107

BAD-02-08-10988

ACTION

Two-thirds requirement blocks budget and greater school funding

Despite intense efforts by CTA, its Education Coalition partners, and school supporters, on the last day of the regular state legislative session, lawmakers were unable to secure the two-thirds vote needed to approve a pending California budget version that would have boosted school spending by more than \$4 billion above Gov. Arnold Schwarzenegger's May budget proposal.

In a test in the Assembly, the Democrats' California Jobs Budget — AB 1609 (Blumenfeld) — garnered 48 yes votes and 25 no votes. Under the state's arcane requirements, budgets must receive a two-thirds supermajority — 54

votes in the Assembly and 27 in the state Senate — in order to be approved.

The pro-education California Jobs Budget, which would have allocated about \$52 billion to schools, received support from all Assembly Democratic legislators. It was opposed by all Assembly Republicans.

For their own part, the Assembly Republicans were able to muster only 25 yes votes for the governor's May Revision budget version — contained in SB 873 (Hollingsworth) — which would provide schools with only \$48.9 billion in Proposition 98 spending.

"Year after year, a small band of legislators has held the state

budget hostage to their ill-advised opposition to raising new revenues and closing tax loopholes that benefit corporations and wealthy individuals," says CTA President David A. Sanchez. "This unconscionable situation is why we are supporting Proposition 25 — the On-Time Budget Act of 2010 — which will reduce the votes needed to pass a budget to a simple majority and penalize lawmakers if they miss the constitutional budget deadline."

As the *Educator* went to press, it remained unclear whether lawmakers would be able to reach a budget agreement. While the state constitution requires the Legislature to send the gov-

ernor a spending plan by June 15, the document contains no penalties for legislators' failure to do so. The Legislature can be called back by the Assembly speaker and the Senate president pro tem to continue their work on the budget. If a new budget is not approved by Nov. 30, responsibility for creating and passing one would fall to the new Legislature and very possibly to the new governor.

Bills introduced in this legislative session must be voted out by Aug. 31 or they die for this year. The governor has until Sept. 30 to sign or veto bills passed by the Legislature on or before Sept. 1.

LEN FELDMAN

Education Jobs Bill will help rehire over 13,000 California educators

Due to the hard work of educators all across the country this summer, Congress approved the Education Jobs Bill in August, designed to provide education funding under the American Recovery and Reinvestment Act. The action brings \$1.2 billion to California to help retain and rehire about 13,000 educators.

CTA members came out in force with e-mails, letters and texts. More than 10,000 contacts were made with California's sena-

tors and representatives in Congress. Educators, including many laid-off members, traveled to Washington, D.C., to show their support for the bill.

Educators voiced to federal leaders the seriousness of the situation in California, which has seen more than 32,000 layoffs over the past three years and already has the largest student-to-teacher ratio in the country.

Under a bill approved by the California Legislature — SB 847 by Senate President Pro Tem Dar-

rell Steinberg (D-Sacramento) — the money will be sent to local school districts according to a base-revenue-limit formula.

The bill stipulates that all of the money must be used specifically to rehire laid-off educators or restore salary cuts due to state budget cuts. The funds will be available in the 2010-11 school year to "retain, recall, or rehire former employees and to hire new employees to provide early childhood, elementary, or secondary educational services." Money will go out to local school

districts by mid-September.

At press time, SB 847 was headed to the governor for his signature.

CTA was joined in its support for the measure by organizations including United Teachers Los Angeles, the California School Employees Association, the League of Women Voters of California, the Los Angeles Unified School District, the Santa Ana Unified School District, and the Small School Districts Association.

LEN FELDMAN

Assembly panel defeats CTA-opposed rigid layoff bill

After a barrage of e-mails, letters and phone calls from CTA members, the Assembly Appropriations Committee voted overwhelmingly to defeat a CTA-opposed measure that would have deprived students in decile 1-3 schools of their most experienced educators and undermined teacher seniority rights. CTA-opposed SB 1285/SB 691 (Steinberg) received only three votes from the 17-member panel, with nine votes needed for passage.

The bill would have tied the hands of local decision makers in determining the best layoff procedures to meet the needs of students and schools in the district. It would have also prohibited districts from laying off more teachers at decile 1-3 schools than the average proportion in the district. And it would have required school districts to keep less experienced teachers and lay off more experienced teachers regardless of performance.

CTA members stressed to lawmakers that there was no data to support the assumption that this rigid formula would improve instruction. However, a great deal of data shows that students perform better with more experienced teachers. The unintended consequence of the measure would certainly have been that teachers with less than five years experience would have comprised the staff of these high-priority schools.

SB 1285/SB 691 would have established an unproven procedure that would have eliminated local control and aggravated the destabilizing and traumatic impacts of teacher layoffs on schools and students.

The overwhelming defeat of the measure demonstrates the power of educators who know firsthand how this bill would hurt the students that need help the most.

LEN FELDMAN

Here's how the committee voted

- Voting for the bill and against CTA's "Oppose" position:**
 Assembly Members Charles Calderon, Joe Coto, and Mike Davis.
- Voting against the bill and in alignment with CTA's position:**
 Assembly Appropriations Chair Felipe Fuentes, Vice Chair Connie Conway, and Assembly Members Jeff Miller, Nancy Skinner, and Tom Torlakson.
- Not voting:**
 Assembly Members Mike Gatto, Isadore Hall III, Jose Solorio, Kevin de Leon, Chris Norby, Jim Nielsen, Steven Bradford, and Diane L. Harkey. Assembly Member Alberto Torrico was not in the room during the vote. Their abstentions or absences had the same effect as voting against the measure.

Mini Grants

Continued from page 28

provided with tremendous experience on "How everything works."

DIANE HUNT ROBERTS (SAN LUIS OBISPO), \$5,000. This project is designed to enhance the special education services provided by staff from the County Office of Education. The grant enables the four professionals (classroom SDC teacher, speech/language pathologist, occupational therapist and adapted physical education specialist) who work with special education students to integrate their efforts. This "core" collaboration among parents, professionals and students will enable students to identify and demonstrate abilities in

three main areas: focus, strength and caring.

EMILY SIMPSON (CUPERTINO), \$5,000. This project centers around the development of a community garden, located on the Dilworth Elementary School campus. The garden will bring together all members of the school community and integrate various curricula in an engaging and meaningful way. It will enable the staff to supplement the science curriculum with a hands-on community building opportunity and to reinforce positive strength-based character traits, such as citizenship and responsibility. Ultimately, staff and students would like to establish

a local Farmer's Market to sell produce and seeds and help sustain the continuing cost of the school garden.

CYNTHIA SOARES (GRIDLEY), \$4,994. This project is to implement Conscious Discipline (CD) into six classrooms at McKinley Primary School (one kindergarten and five first-grade classrooms). The school district will be simultaneously providing parent education classes in the community in both English and Spanish. CD is an integrated social emotional intelligence and character development classroom management system based on current brain research. It is built on three strength-based principles:

safety, connections and problem solving.

ALLEN TENG (SAN MARCOS), \$5,000. This project is designed to emphasize student engagement and active participation in math and science at Woodland Park Middle School. Putting the school on warp speed toward the 21st century, this grant hopes to capitalize on new breakthroughs in augmented reality, which overlays digital images and information on real-world settings. The grant will be used to purchase applicable software that will enable staff to do teacher-driven experiments and demonstrations that captivate adolescent imaginations.

2008 Summary Annual Report

For CTA Economic Benefits Trust Member Welfare Benefit Plan

This is a summary of the annual report of the California Teachers Association Economic Benefits Trust Member Welfare Benefit Plan, EIN 94-0362310, Plan No. 590, for the period Sept. 1, 2008, through Aug. 31, 2009. The annual report has been filed with the Employee Benefits Security Administration, U.S. Department of Labor, as required under the Employee Retirement Income Security Act of 1974 (ERISA).

Insurance Information: The plan has contracts with Standard Insurance Company to pay life insurance, AD&D, temporary disability and long-term disability claims incurred under the terms of the plan. The total premiums paid for the plan year ending Aug. 31, 2009, were \$33,164,066.

Because they are so-called "experience-rated" contracts, the premium costs are affected by, among other things, the number and size of claims. Of the total insurance premiums paid for the plan year ending Aug. 31, 2008, the premiums paid under such "experience-rated" contracts were \$33,164,066 and the total of all benefit claims paid under these experience-rated contracts during the plan year was \$21,320,581.

The Plan finances, to specified members of CTA, death and dismemberment benefits through the CTA Death and Dismemberment Plan, a health information and well-baby program, a consumer benefits education program, a retiree discount vision program and, intermittently, a premium holiday benefit. These benefits are self-funded by the Plan and are not insured by an insurance company.

Basic Financial Statement: The value of plan assets, after subtracting liabilities of the plan, was \$64,274,558 as of Aug. 31, 2009, compared to \$65,548,238 as of Sept. 1, 2008. During the plan year the plan experienced a decrease in its net assets of \$1,273,680. This decrease includes unrealized appreciation and depreciation in the value of plan assets; that is, the difference between the value of the plan's assets at the end of the year and the value of the assets at the beginning of the year or the cost of assets acquired during the year. During the plan year, the plan had total income of \$34,353,346 including employee contributions of \$33,164,066, realized losses of \$1,386,371 from the sale of assets, and earnings

from investments of \$2,575,651.

Plan expenses were \$35,627,026. These expenses included \$1,518,599 in administrative expenses and \$34,108,427 in benefits paid to participants and beneficiaries.

Your Rights to Additional Information: You have the right to receive a copy of the full annual report, or any part thereof, on request. The items listed below are included in that report: 1) an accountant's report; 2) financial information and information on payments to service providers; 3) assets held for investment; and 4) insurance information, including sales commissions paid by insurance carriers.

To obtain a copy of the full annual report, or any part thereof, write the office of Risk Management/Member Benefits, California Teachers Association [the Plan administrator], 1705 Murchison Drive, Burlingame, CA 94010, (650) 697-1400. The charge to cover copying costs will be 25 cents per page.

You also have the right to receive from the plan administrator, on request and at no charge, a statement of the assets and liabilities of the plan and accompanying notes, or a statement of income and expenses of the plan and accompanying notes, or both. If you request a copy of the full annual report from the plan administrator, these two statements and accompanying notes will be included as part of that report. You also have the legally protected right to examine the annual report at the main office of the plan (California Teachers Association, 1705 Murchison Drive, Burlingame, CA 94010) and at the U.S. Department of Labor in Washington, D.C., or to obtain a copy from the U.S. Department of Labor upon payment of copying costs. Requests to the Department should be addressed to: Public Disclosure Room, Room N1513, Employee Benefits Security Administration, U.S. Department of Labor, 200 Constitution Avenue NW, Washington, DC 20210.

SEND US YOUR COMMENTS



If any of the stories in the *California Educator* pique your interest, let us know your thoughts and we may publish your letter. Please include your full name, local association and phone number or e-mail address in the event that we want to contact you.

Letters may be sent via mail, fax or e-mail.

address: California Educator Magazine
CTA Communications
1705 Murchison Drive
Burlingame, CA 94010-4583

fax: (650) 552-5002

e-mail: editor@cta.org

Heads up!

Conferences

Gay, Lesbian, Bisexual, Transgender Issues Conference October 29-31, 2010

Westin Mission Hills, Rancho Mirage

CTA's Gay, Lesbian, Bisexual, and Transgender Issues Advisory Committee (GLBTIAC) is proud to present the second annual CTA conference addressing issues involving GLBT teachers, students and community. This conference is open to all CTA members and will serve as a venue to discuss a variety of subjects affecting the entire membership and California's youth. Participants will have a variety of workshops to choose from, organized into three strands addressing the needs of the membership, the students and the community. Register online at www.cta.org/conferences.

Secondary Literacy Summit X December 8-9, 2010

Hilton Orange County, Costa Mesa

Sessions highlight best practices for improving adolescent literacy achievement. Keynote speakers, workshop sessions, and school panels will focus on reading, academic vocabulary, comprehension, writing, and content literacy. Multiple sessions will address instructional strategies for closing achievement gaps for English learners and students with special needs. School presentations will feature secondary school teams who are successfully improving literacy achievement for all students. There will also be sessions on the Common Core Standards and Rtl. For more information, visit www.cacompcenter.org/secondaryliteracy.

Deadlines

Incentive grants for winter conferences October 22, 2010

Attendees of CTA's winter conferences are encouraged to apply for minority and small chapter incentive grants, which pay for transportation expenses, conference fee and materials, and housing based on double occupancy. Apply by **Friday, Oct. 22**. Minority incentive grants are offered to members of racial-ethnic minority groups to encourage minority leadership within CTA. Small chapter incentive grants are offered to members from chapters representing 100 or fewer persons for collective bargaining. The Issues Conference (**Jan. 14-16**) also offers incentive grants for small chapters with 25 or fewer, 50 or fewer, 51-100, and 101-200 unit members. Additionally, white male and GLBT incentive grants are available for the Equity and Human Rights Conference (**March 4-6**). You can register and apply for incentive grants online at www.cta.org/conferences.

Voluntary contribution change November 1, 2010

CTA annual dues include a voluntary contribution of \$20. New members are automatically enrolled in the default allocation of \$15 to support CTA advocacy efforts and \$5 to the Foundation for Teaching and Learning, which provides scholarships, grants, awards and disaster relief. If new members wish to change their allocation, request a partial refund, or opt out of the contribution, they must do so within 30 days from the date of enrollment. Previously enrolled members will continue with

Continued on page 37



WATCH AT:

www.apu.edu/stories/ron

Ron Letourneau '88

Principal, Santa Fe Middle School, Monrovia, CA

Further your career in education.

Now more than ever, our children need great educators. If you're considering a career change or continuing your education, we invite you to explore Azusa Pacific University. With programs for teachers, counselors, coaches, and administrators, we're confident APU has a degree for you.

APU offers:

- Convenient classes 1 night a week at 1 of 8 Southern California locations.
- More than 36 credential and master's degree opportunities.
- Accelerated programs that allow you to earn your degree in just 12-18 months.
- NCATE-accredited programs recognized by all 50 states and internationally.

Programs start five times throughout the year. Contact us today!

Call (800) 825-5278

Click www.apu.edu/explore/education

Email graduatecenter@apu.edu



AZUSA | HIGH DESERT | INLAND EMPIRE | LOS ANGELES | MURRIETA
ORANGE COUNTY | SAN DIEGO | VENTURA COUNTY | ONLINE

11031

CTA-sponsored and co-sponsored legislation for 2010

	BILL #		STATUS
UNIVERSAL HEALTHCARE Leno	SB 810	Would establish a single-payer health insurance system in California. <i>(Co-sponsored bill)</i>	Assembly floor
RETIREE HEALTH BENEFITS Buchanan	AB 1814	Would provide that the Fair Employment and Housing Act does not prohibit an employer from reducing health benefits when a retiree becomes eligible for Medicare. <i>(Co-sponsored bill)</i>	Signed into law
CHARTER SCHOOLS Swanson	AB 2320	Would increase the role of teachers in the design, operation and governance of charter schools, and allow only school boards to authorize non-statewide charters.	Died in Senate Education

Photo by Glen Korengold

Sacramento schools

Continued from page 13

be going into effect instead.

"It came down as a mandate," recalls York, who was put into the Visual and Performing Arts (VAPA) SLC. "Basically, we were told: This is what you're going to do."

Instead of having English teachers on the same floor, they were divided up to be with their SLCs, and it became difficult to collaborate. For a while they tried to schedule meetings, says York, but there were so many SLC meetings that subject matter collaboration fizzled out. Class siz-

es were large, since there were fewer teachers per subject, and scheduling problems were rampant.

All SLCs are considered equal, but some are more equal than others. Motivated students enroll in the PACE (Program in America and California Exploration) program with a mandatory summer school component at CSU Sacramento and AP classes. To the dismay of teachers in other SLCs, a disproportionate amount of funding also goes to PACE.

"It put a real rift in the

school because things are unequal," says York. "In VAPA, we were not getting any money to support our very good band or choir."

The Gates grant money has dried up, the SLCs are still in place, and many of them are scraping by without adequate support.

"Bill Gates has lots of money and decided we need better schools," adds York. "I agree with

him on that. But I don't know why he thought he knew how to do it or why he thought small learning communities were a good idea. There had been no studies to see if they actually worked, but he poured millions of dollars into this. If you ask me, the money could have been spent in much better ways for smaller class sizes, books and tutoring."

Social media

Continued from page 24

tallied 301,000 e-mails and 100,000 calls to Congress. More than 35,000 people became active fans of the Speak Up for Education & Kids campaign on Facebook, and 145,000 new member lobbyists signed up to take action.

In April, teachers in Florida, led by the Florida Education Association, convinced Republican Gov. Charlie Crist to veto legislation passed by the Legislature that would have ended due process and implemented an egregious merit pay system based on student test scores. Along the way, teachers set up 15 separate Facebook pages that drew a membership of 200,000 people. Crist himself said calls to his office ran 5-to-1 against the bill and that he had never faced as much political pressure on any piece of legislation.

"We're seeing social media as powerful new tools in engaging our members — especially our younger members — to become involved in this high-stakes election," says CTA President David A. Sanchez.

CTA knows that although using social media can be a powerful communications tool and a necessary addition to any well-planned campaign, traditional campaign activities are still effective. Members will have a chance to participate in traditional door-to-door activities, postcard-writing parties and the tried-and-true phone banks as well.

"We're going to cover all of our bases," says Sanchez, "to see that our students, teachers and schools come out winners in the November elections."

Dina Martin

Where is your career taking you? With a J.D., your options are endless.

If you want to sit for the California Bar, we have the most cost effective answer.



- In house zero percent financing
- Small class size
- Classes meet only twice a week
- Courtroom training skills curriculum

Earn your J.D. either online, or at our Carlsbad or Los Angeles campus and review facility. The online option allows you to study from your home, while traveling, or anywhere there is an Internet connection.



Apply online at
CaliforniaMidland.com
or call: 760-929-5900

WE DO NOT REQUIRE THE LSAT FOR ADMISSION

Heads up!

Continued from page 35

the contribution they chose last year, which remains in effect until changed by the member. If they wish to change their allocation or opt out, they must do so during the window from **Aug. 1 to Nov. 1**. No action is necessary if you are satisfied with your current contribution. To view your contribution online, change your allocation or opt out, visit www.cta.org/About-CTA/Voluntary-Contribution.

GLBT "Guy deRosa" Safety in Schools Program

November 5, 2010

This program provides grants to support projects and presentations that promote understanding and respect for Gay, Lesbian, Bisexual and Transgender persons, in addition to scholarships for members enrolled in a teacher/counseling credential or graduate program who understand the importance of GLBT educators as role models. Apply by **Friday, Nov. 5**. For more information, visit www.cta.org/About-CTA/CTA-Foundation/Scholarships.

CATESOL:

What We Do for ELL Teachers



- Provide legislative advocacy in both the California and Nevada state legislatures and work with the international TESOL organization in its national legislative advocacy on behalf of teachers of English language learners
- Provide opportunities for professional development activities at the state, regional, and local levels and online
- Provide opportunities for building the professional networking that assists teachers in improving themselves and the environments in which they work
- Promote the exchange of information via the annual refereed *CATESOL Journal*, the quarterly *CATESOL News*, the electronic *CATESOL Monthly News*, and ongoing interest-group and teaching-level Listservs

JOIN NOW!

\$10 one-time membership discount for CTA members who mention this ad when joining or rejoining.
(Promotion code: CTA-9834)

CATESOL

19881 Brookhurst St., Ste. C-133
Huntington Beach, CA 92646
(559) 366-4936 Fax (888) 832-0501
E-mail: catesol@catesol.org
Web site: <http://catesol.org>



New!

Introducing the Clear Credential Program (Single and Multiple Subject)

The UC San Diego Extension SB 2042 Clear Credential program is designed for public, charter and private school teachers who are employed in a school or district that do not have an Induction program.

After completing the program, students can then initiate the formal recommendation to the California Commission on Teacher Credentialing.

The new UC San Diego Extension Clear Credential Program is:

- 100% online.
- designed to meet the new standards defined by the CCTC.
- one of the first programs to be made available under the new CCTC standards.
- specifically designed to be **completed within one year**.
- UC San Diego Extension is now accepting applications for the new program.

To view credential requirements, the program FAQ and to download an application please visit our Clear Credential program page at extension.ucsd.edu/clearcredential.

UC San Diego Extension also offers accessible and affordable online programs for K-12 and Postsecondary Educators.

- New courses begin every month
- Most programs can be completed online within 1 year
- Interactive, Research-Based Programs with Practical Classroom Application

Programs include:

- CLAD Through CTCL
- CCTC-Approved Reading Certificate
- Career and Technical Education (CTE)
- College Counseling
- Gifted and Talented Education (GATE)
- Teaching Adult Learners
- Teaching Online
- Professional Development/ Salary Point Coursework

For more information, please contact
Morgan Appel, Director of Education at: (858) 964-1064 or mappel@ucsd.edu

extension.ucsd.edu/education

Zoe Walrond begins every KRFH Workshop class by having her students chant:

*Give me a K!
Give me an R!
Give me an F!
Give me an H!*

Reminiscent of the band Country Joe and the Fish, the chant epitomizes the freewheeling, hippy-ish spirit of KRFH — K-Radio Free Humboldt — at Humboldt State University, and Walrond's team-building approach to teaching students how to run a radio station.

Walrond, an award-winning broadcast news reporter for 30 years and a news anchor on radio and television stations in Denver, Kansas City and Los Angeles, and for National Public Radio, has been at the university five years. She teaches the workshop for the radio class and is the faculty adviser for the radio station that's run by students.

Her students say that Walrond has been an inspiration in helping them achieve success.

"She's taught us about news judgment and about responsibility," says Ashley Bailey, news director of the station. "She wants for us to have a good time, and for KRFH to be cool, but she has a lot of respect for KRFH and wants us to also have that respect. She has made us realize that being on the radio is a privilege that has to be earned. She has been a real mentor for many of us."

Walrond, a California Faculty Association member, is proud that KRFH students received the National Student Production Award for best newscast in the College Broadcasters Inc. competition. The winning broadcast was an update on the arrest of a Somali pirate and the possibility that he might be tried in the United States, with a "music bed" under the story for added tension.

"I submitted the newscast and thought it was a long shot," says Walrond. "When they won, I was blown away."

KRFH serves as a training ground for those aspiring to be future broadcasters — as well as those who want to have fun. In addition to being at the microphone, teams of students sell advertising spots, handle public relations, produce shows, and handle Facebook and Twitter accounts. Walrond makes sure that they also learn



ABOVE: Zoe Walrond teaches the KRFH Workshop at Humboldt State University. **RIGHT:** DJs Rory Smith and Tyler Collins, co-hosts of "Just the Two of Us."



Photos by Scott Buschman

responsibility: If they can't find a substitute to fill in for them on the air, their grade for the course drops an entire letter.

On the air seven days a week, KRFH broadcasts throughout the campus and can also be heard on www.krffh.net. In an era when corporations decide what kind of music radio stations can play, KRFH gives a break to musicians across the country who are trying to get their music heard. Bands from Brooklyn, San Francisco, Massachusetts, Salt Lake City and Alaska have sent their CDs to the station in hopes of airtime.

Students in the KRFH Workshop are on the air for one hour per week, while students in the Advanced Workshop get two hours a week. Shows have names as colorful as the 1940s-style murals that adorn the station's walls — DJ Toni Fluke's "Fluke Nuke 'Em Show," DJ Chicken Wing's "Clucking Hour of Power," Rob the Lobster's "Humboldt Hangover Blues: Pounding Beats for Throbbing Temples," and other names, some of which can't be repeated.

Walrond says her students love it so much, it's like a "cult" for many of them, who continue their affiliation with the station after graduation.

"It's entertaining and super fun," says Tyler Collins, who co-hosts "Just the Two of Us" with Rory Smith, featuring sports talk with a "heap-

ing" side of music. "There could be 10 people listening or 10,000, but you get to talk about the things that interest you, play the music you like and sometimes get requests."

"I just love getting the experience," says Lydia Katz, whose show, "Redwood Rebe Radio," is about Judaism. "I'm not at all shy. My roommates said, 'Oh my God, they gave you a show? What have they done?' But I just love to talk."

As faculty adviser, Walrond serves as a general manager and makes sure students follow all of the FCC guidelines such as not using profanity, imbibing alcohol or drugs on the air, or surreptitiously recording callers — especially school administrators — without informing them that they are being taped.

"The students usually self-police," she says. "And if there's a problem, I hear about it."

Some of her students go on to work in professional broadcasting jobs, while others go into other careers and benefit from the learning experience.

"I love watching them grow in self-confidence," says Walrond. "It's so rewarding. For me, it's all about the students."

SHERRY POSNICK-GOODWIN



University of San Diego

DIVISION OF CONTINUING EDUCATION
Programs for Educators



Chess Series: From Game Basics to a full Classroom Program

Learn how to integrate chess into your curriculum! This Series is designed to encourage K-12 educators of all chess ability levels, from beginner to expert, to use the game of chess to promote student learning and improve academic success.

- NEW!** Chess Basics for the Novice
EDU 534CQ (1 Semester Unit)
- Chess for Educators
EDU 534CR (2 Semester Units)
- Chess in the Curriculum
EDU 534CS (2 Semester Units)
- Integrating Chess in the Curriculum
EDU 534CT (1 Semester Unit)



Science SERIES

Teaching
Elementary Science
EDU 560SA & SB
3 Semester Units

Planning &
Implementation
Science
EDU 559ZA-ZF
1 and 2 Semester Units

Real World Science
3, 2 or 1 Semester Units

- Building and Launching Your Own Rocket EDU 560AD
- Electromagnetic Waves: Visible Light, X-Rays and UV Radiation EDU 560DA
- Mechanical Waves: Sound, Seismic Waves and Water Waves EDU 560DB
- Let's Build a Demo: A LED Audio Transmitter and Receiver EDU 560DC



TECHNOLOGY COURSES

Increase your ability to keep records, design lessons, do research and communicate effectively by enhancing your technology knowledge!

- The Tech Savvy Teacher
EDU 508ZF
- Information Literacy
EDU 508ZG
- Internet Projects for the Classroom
EDU 508ZH
- All About WebQuests
EDU 508ZI
- Going Public: Writing & Publishing on the Web
EDU 508ZJ
- Stop, Look & Listen:
Digital Audio-Visual Resources
EDU 508ZK
- Internet Safety
EDU 508ZL
- Digital Storytelling
EDU 508ZM
- Web Design for the Educator
EDU 580WD
- WebQuest Publication
EDU 580WH
- Microsoft Office for the Educator:
Level I - EDU 581BC
Level II - EDU 581CC
- PowerPoint for Educators
EDU 581CF
- Microsoft Office 2007
for the Educator
EDU 581CE

Teaching Math to Everyone Series



Develop strategies that will significantly improve your ability to teach math to all of your students... even the most anxious students will be excited about your new approach to teaching math. The series consists of four courses:

- Math for Everyone
EDU 534SA
(2 Semester Units)
- Teaching Math Cooperatively
EDU 534SB
(1 Semester Unit)
- Reducing Math Anxiety
EDU 534SC
(1 Semester Unit)
- Using Writing to Teach Math
EDU 534SD
(2 Semester Units)

Professional Teachers Program Teacher Online Courses (created by Teachers Network)

Fall classes begin October 4 and are limited enrollment!

- ★ **NEW!** Promoting Healthy Lifestyle Skills
- ★ Literacy
- ★ Classroom Management (Elementary & Secondary)
- ★ Aligning Standards
- ★ Teaching Social Skills
- ★ Inclusion
- ★ Working with Families
- ★ Differentiation
- ★ **NEW!** How To Use The Internet In Your Classroom
- ★ **NEW!** Smart Use of Your Interactive Whiteboard in the Classroom
- ★ **NEW!** Reading and Writing in the Digital Age



Looking for Scheduled Classes?

Sign-up online for local classes in your area! Visit www.usd-online.org and click on Scheduled Classes link!

Prior district approval for salary advancement units is recommended and the responsibility of each student. NOTE: One Semester Unit is equivalent to 15 hours.

www.usd-online.org

Tired of Rising Costs at the Big Banks? Switch Your Accounts to First Financial and Save Money!



BETTER VALUE

*We've Been Helping CTA Members
Save Money for Over 75 Years!*

**Save Money with our Auto Loans Rates
and our Auto Buying Service**

Save money with our budget-friendly loans and
we can save you money on your new car, too!

Free Checks for Life*

With any First Financial checking account!
Why pay elsewhere? Plus, you'll have access to
more no-surcharge ATMs than the big banks!

We give you better banking than at the banks!

FIRST FINANCIAL

C R E D I T ♦ U N I O N

(800) 537-8491 ♦ www.ffc.u.org

Endorsed by:



All loans are subject to credit approval and all FFCU policies and procedures. Rates, terms and conditions subject to change without notice. Other restrictions may apply. Please call for complete account/product information or refer to your Truth-in-Savings disclosure. FFCU is an equal opportunity lender. *Free Checks for Life applies to FFCU Image checks; restrictions apply.

BETTER SERVICE

*We're Dedicated to
Member Satisfaction!*

You don't have to take
just our word for it.

Over 95% of our members
said they would recommend
First Financial to family/colleagues!

Proudly Serving CTA Members for Over 75 Years!